



Instruction Manual
Compressors

CLINIC 3.40

CLINIC DRY 3.40 H

CLINIC DRY 3.40 HS

CE EAC

EN



INDEX

| | |
|--|-----------|
| INTRODUCTION | 4 |
| STATEMENTS AND TESTING | 5 |
| Statement of delivery of the instruction manual | 5 |
| Testing and commissioning certificate | 6 |
| EC DECLARATION OF CONFORMITY | 7 |
| STATEMENT AND CE MARK | 8 |
| Statement and CE mark | 8 |
| GENERALI | 9 |
| Importance of the manual | 9 |
| Consultation notes | 10 |
| State "machine off" | 10 |
| Authorized operators | 11 |
| Abbreviations | 13 |
| All rights reserved | 13 |
| Warranty | 14 |
| TECHNICAL DESCRIPTION | 15 |
| Name of models | 15 |
| Names of parts | 16 |
| Dimensions of the machine | 18 |
| Technical data | 19 |
| Intended use of the machine | 20 |
| Source of energy supply | 20 |
| Products used for the operation | 21 |
| Phases of operation | 21 |
| Reasonably foreseeable misuse | 21 |
| TRANSPORTATION AND HANDLING | 22 |
| Transportation of the machine | 22 |
| Packaging | 22 |
| Handling of packaging with a forklift or transpallet | 22 |
| Unpacking | 22 |
| Manual handling of the machine | 24 |
| Positioning of the machine | 25 |
| INSTALLATION | 26 |
| General warnings | 26 |
| Pneumatic connection | 26 |
| Electric connection | 27 |
| SAFETY | 28 |
| Safety devices | 28 |
| Personal protective equipment (PPD) | 30 |
| Residual risks | 30 |
| Safety signs | 31 |
| USE AND OPERATION | 32 |
| Places occupied by authorized operators | 32 |
| Pressure switch | 33 |
| Prior to ignition | 34 |
| Turning on the machine | 34 |



Resettable thermal 36
 Turning off the machine 36
 Emergency stop..... 36
 Activation after an emergency stop 38
 Intervention of the safety valve..... 38
TROUBLESHOOTING..... 39
MAINTENANCE 40
 Every week 41
 Every month 42
 AFM 30 cartridge replacement 43
 AF 30 cartridge replacement 43
 Sterilization filter replacement..... 44
 Extraordinary maintenance..... 45
DECOMMISSIONING 45
 Storage 45
 Demolition 45
SPARE PARTS 46
ATTACHMENTS 46

INTRODUCTION

Dear Customer, first of all, we wish to thank you for the confidence you gave us by purchasing your new “COMPRESSOR”.

We are sure that your expectations will be met, given the level of technology achieved by our products with a continued commitment on a daily basis, which encourages us to grow, to know how to deal with the constant changes in technology expertise, manufacturing and sales.

We feel sure we can meet your future requirements, therefore, feel free to contact us. We will be happy to offer you all our experience and knowledge to answer any question you may have.

| INFORMATION TO THE CUSTOMER | | |
|--|-----------|--|
| DOCUMENT | PAGE | TO DO |
| STATEMENT OF DELIVERY OF THE INSTRUCTION MANUAL | 5 | The authorised operators must complete and sign to confirm the delivery and reading of the instruction manual. |
| TESTING AND COMMISSIONING CERTIFICATE | 6 | Give to the test technician of the Manufacturer or to the Authorized Dealer a copy of page 6 completed in all its parts. |
| PRODUCT REGISTRATION FOR WARRANTY VALIDATION | 14 | See paragraph “WARRANTY” - Section 2) Page 14. |



STATEMENTS AND TESTING

STATEMENT OF DELIVERY OF THE INSTRUCTION MANUAL

The employer, to the extent required by applicable law on safety and health of workers at work, hereby declares it has delivered to the authorized operators this manual for the correct information and training on use and maintenance of the machine.

| AUTHORIZED OPERATORS | DATE | SIGNATURE FOR RECEIPT |
|----------------------|-------|-----------------------|
| Mr. _____ | _____ | _____ |
| Mr. _____ | _____ | _____ |
| Mr. _____ | _____ | _____ |
| Mr. _____ | _____ | _____ |
| Mr. _____ | _____ | _____ |
| Mr. _____ | _____ | _____ |
| Mr. _____ | _____ | _____ |
| Mr. _____ | _____ | _____ |
| Mr. _____ | _____ | _____ |
| Mr. _____ | _____ | _____ |

Before filling in the table, photocopy it for future reference.



| TESTING AND COMMISSIONING CERTIFICATE | DATE _____ |
|--|------------------------------|
| Designation: compressor | Name: _____ |
| Model: _____ | Street: _____ |
| Serial No: _____ | City: _____ |
| Manufacture year: _____ | State: _____ |
| <p>This is to certify that the machine in question was tested by: Test technician of the manufacturer or authorized dealer:</p> <p>Mr. _____</p> <p>At the presence of the entrusted operator:</p> <p>Mr. _____</p> <p>At the presence of the entrusted operator and Safety Representative:</p> <p>Mr. _____</p> | |
| <input type="checkbox"/> Check for proper installation of the machine. | |
| <input type="checkbox"/> Verification of the correct setting of all the working parameters. | |
| <input type="checkbox"/> Verification of correct operation and intervention of all the safety devices. | |
| <input type="checkbox"/> Commissioning and performance of a work cycle. | |
| <input type="checkbox"/> Possible optimization of the working parameters. | |
| <input type="checkbox"/> Machine stop. | |
| <input type="checkbox"/> Delivery of the instruction manual. | |
| <p>SIGNATURE Test Technician of the Manufacturer or Authorized Dealer</p> | <p>Safety Representative</p> |

GENTILIN S.r.l.

Via delle Tezze 20/22 - 36070 Trissino (VI) Italy
P.Iva/VAT 01262520248

[IT] **Dichiara che la seguente macchina, compressore volumetrico a pistoni senza lubrificazione collegato coassialmente a motore elettrico asincrono è conforme alle disposizioni delle seguenti direttive**

2006/42/CE Direttiva del Parlamento Europeo e del Consiglio del 17 maggio 2006, relativa alle macchine e che modifica la direttiva 95/16/CE (rifusione).

Direttiva **2014/29/UE** del Parlamento Europeo e del Consiglio del 26 febbraio 2014.

Direttiva **2014/30/UE** del Parlamento Europeo e del Consiglio del 26 febbraio 2014, che sostituisce la 2004/108/CE Direttiva del Parlamento Europeo e del Consiglio del 15 dicembre 2004, concernente il ravvicinamento delle legislazioni degli Stati Membri, relative alla compatibilità elettromagnetica e che abroga da Direttiva 89/336/CEE 97/23/CE (Art. 3.3).

Direttiva **2014/35/UE** del Parlamento Europeo e del Consiglio del 26 febbraio 2014, che sostituisce la 2006/95/CE del Parlamento Europeo e del Consiglio del 12 dicembre 2006.

Direttiva **2000/14/CE** del Parlamento Europeo e del Consiglio, del 8 Maggio 2000 e successive integrazioni

È conforme alle norme armonizzate EN 1012, EN 60204-1, EN 60335-1.

Persona autorizzata a costituire il Fascicolo Tecnico: **Gentilin Giuseppe**, in qualità di Responsabile Tecnico

[DE] **erklärt, dass die folgenden Maschinen, Volumenkolbenkompressor ohne Verschmierung koaxial mit einem asynchronen Elektromotor verbunden mit den Vorschriften der folgenden Richtlinien übereinstimmen:**

Richtlinie **2006/42/CE** des europäischen Parlaments und des Rates vom 17. Mai 2006 über Maschinen und zur Änderung der Richtlinie 95/16/EG (Neufassung).

Richtlinie **2014/29/UE** des europäischen Parlaments und des Rates vom 26. Februar 2014.

Richtlinie **2014/30/UE** des europäischen Parlaments und des Rates vom 26. Februar 2014, die die Richtlinie 2004/108/EG des europäischen Parlaments und des Rates vom 15. Dezember 2004 zur Angleichung der Rechtsvorschriften der Mitgliedstaaten über die elektromagnetische Verträglichkeit und zur Aufhebung der Richtlinie 89/336/EWG 97/23/EG (Art. 3.3) ersetzt.

Richtlinie **2014/35/UE** des europäischen Parlaments und des Rates vom 26. Februar 2014, die die Richtlinie 2006/95/EG des Europäischen Parlaments und des Rates vom 12. Dezember 2006 ersetzt.

Richtlinie **2000/14/CE** des europäischen Parlaments und des Rates vom 8. Mai 2000 und nachfolgende Ergänzungen.

Entspricht harmonisierten normen EN 1012, EN 60204-1, EN 60335-1.

Zur Erstellung der technischen Unterlagen bevollmächtigte Person: **Gentilin Giuseppe**, als technischer Leiter.

[FR] **Déclarer que la machine suivante: compresseur d'air à pistons volumétriques sans huile raccordé coaxialement à un moteur électrique asynchrone, est conforme aux dispositions des directives suivantes**

2006/42/CE Directive du Parlement européen et du Conseil du 17 mai 2006 sur les machines et modifiant la directive 95/16/CE (refonte).

2014/29/UE Directive du Parlement européen et du Conseil du 26 février 2014

2014/30/UE Directive du Parlement européen et du Conseil du 26 février 2014, remplaçant la directive 2004/108/CE du Parlement européen et du Conseil du 15 décembre 2004, concernant le rapprochement des législations des États membres relatives à la compatibilité électromagnétique et abrogeant Directive 89/336/CEE.

2014/35/UE Directive du Parlement européen et du Conseil du 26 février 2014, remplaçant la directive 2006/95/CE du Parlement européen et du Conseil, du 12 décembre 2006.

2000/14/CE Directive du Parlement européen et du Conseil du 8 mai 2000 et compléments ultérieurs.

Conforme aux normes harmonisées EN 1012, EN 60204-1, EN 60335-1.

Personne habilitée à préparer le Dossier Technique: **Gentilin Giuseppe**, en qualité de Responsable Technique

[EN] **Declares that the following machine, volumetric piston air compressor oil-less coaxially connected to an asynchronous electric motor, complies with the provisions of the following directives**

2006/42/EC Directive of the European Parliament and the Council of 17 May 2006 on machinery and amending Directive 95/16/EC (recast).

2014/29/UE Directive of the European Parliament and of the Council of 26 February 2014

2014/30/UE Directive of the European Parliament and of the Council of 26 February 2014, replacing 2004/108/EC Directive of the European Parliament and of the Council of 15 December 2004, on the approximation of the laws of the Member States relating to electromagnetic compatibility and repealing Directive 89/336/EEC.

2014/35/UE Directive of the European Parliament and of the Council of 26 February 2014, replacing Directive 2006/95/EC of the European Parliament and Council, of December 12, 2006.

2000/14/CE Directive of the European Parliament and the Council of 8 May 2000 and subsequent additions.

Complies with harmonized standards EN 1012, EN 60204-1, EN 60335-1.

Person authorized to prepare the Technical Dossier: **Gentilin Giuseppe**, in quality of Technical Manager

[ES] **Declara que las siguientes máquinas, compresor de pistón volumétrico sin lubricación conectado coaxialmente a un motor eléctrico asincrónico son conformes a las disposiciones de las siguientes Directivas**

2006/42/CE Directiva del Parlamento Europeo y del Consejo del 17 de mayo de 2006 relativa a las máquinas y que modifica la Directiva 95/16/CE (refundida).

2014/29/UE Directiva del Parlamento Europeo y del Consejo del 26 de febrero de 2014

2014/30/UE Directiva del Parlamento Europeo y del Consejo del 26 de febrero de 2014, que sustituye la 2004/108/CE Directiva del Parlamento Europeo y del Consejo del 15 de diciembre de 2004 relativa a la aproximación de las legislaciones de los Estados miembros sobre compatibilidad electromagnética y que deroga la Directiva 89/336/CEE 97/23/CE (Art.3.3).

2014/35/UE Directiva del Parlamento Europeo y del Consejo del 26 de febrero de 2014, que sustituye la Directiva 2006/95/CE del Parlamento Europeo y del Consejo del 12 de diciembre de 2006.

2000/14/CE Directiva del Parlamento Europeo y del Consejo del 8 de mayo de 2000 y adiciones subsiguientes.

Cumple con las normas armonizadas EN 1012, EN 60204-1, EN 60335-1.

Persona autorizada a constituir el Fascículo Técnico: **Gentilin Giuseppe**, en calidad de responsable técnico.

[PL] **Oświadczam, że następująca maszyna: wolumetryczna tłokowa sprężarka powietrza, bezolejowa, współosiowo połączona z asynchronicznym silnikiem elektrycznym, jest zgodna z postanowieniami następujących dyrektyw**

2006/42/WE Dyrektywa Parlamentu Europejskiego i Rady z dnia 17 maja 2006 r. W sprawie maszyn zmieniająca dyrektywę 95/16/WE (wersja przekształcona).

2014/29/UE Dyrektywa Parlamentu Europejskiego i Rady z dnia 26 lutego 2014 r

2014/30/UE Dyrektywa Parlamentu Europejskiego i Rady z dnia 26 lutego 2014 r. Zastępująca dyrektywę 2004/108 / WE Parlamentu Europejskiego i Rady z dnia 15 grudnia 2004 r. W sprawie zbliżenia ustawodawstw państw członkowskich odnoszących się do kompatybilności elektromagnetycznej i uchylająca Dyrektywę 89/336 / EWG.

2014/35/UE Dyrektywa Parlamentu Europejskiego i Rady z dnia 26 lutego 2014 r. Zastępująca Dyrektywę 2006/95 / WE Parlamentu Europejskiego i Rady z dnia 12 grudnia 2006 r.

2000/14/WE Dyrektywa Parlamentu Europejskiego i Rady z dnia 8 maja 2000 r. Wraz z późniejszymi uzupełnieniami.

Zgodny z normami zharmonizowanymi EN 1012, EN 60204-1, EN 60335-1.

Osoba upoważniona do przygotowania dokumentacji technicznej: **Gentilin Giuseppe**, kierownik ds. Technicznych

Modello / Matricola
Model / Serial number
Modell- / Seriennummer
Modelo / número de serie
Modèle / numéro de série
Model / numer serijny

Firma (Legale rappresentante)
Signature (Legal Representative)
Unterschrift (gesetzlicher Vertreter)
Firma (Representante legal)
Signature (representant légal)
Podpis (przedstawiciel prawny)





STATEMENT AND CE MARK



MARKING AND TECHNICAL DATA

The CE marking (**Fig. 1**) of the machine indicates compliance with the essential occupational health and safety rules set forth by the European Directives listed in the Declaration of CE Conformity.

The label is black and white printed on adhesive polymeric PVC and has the following dimensions: L = 70 mm - H = 55 mm.

It is applied externally on one side of the machine indicated in **Fig. 1** and states the following data, in a legible manner:

- LOGO, NAME AND ADDRESS OF MANUFACTURER
- CE MARKING
- DESIGNATION OF THE MACHINE (type / model)
- YEAR OF MANUFACTURE
- SERIAL NUMBER
- S1 VALUE
- MAX. WORKING PRESSURE (bar)
- VOLTAGE (V / Hz / A)
- SHAFT ROTATION SPEED (rpm)
- RATED POWER (kW)
- WEIGHT (kg)

| | | | |
|--|--|--|--|
|  Gentilin OIL-FREE. THE NEW NORMAL. | | GENTILIN SRL Via delle Tezze 20-22 36070 Trissino (VI) Italy phone +39 0445 96 2000 info@gentilinair.com | |
| MODEL / MODELLO | | | |
| SERIAL N. / NUM. DI SERIE | | | |
| CLASS OF SERVICE / CLASSE DI SERVIZIO | |  | |
| MAX WORKING PRESSURE/ PRESS. MAX ESERCIZIO ... Bar | | | |
| TENSION / TENSIONEV/.....Hz/.....A | | | |
| SHAFT ROTATION SPEED / VELOCITA' DI ROTAZ... .. rpm | | | |
| RATED POWER / POTENZA NOMINALE. kW | | | |
| WEIGHT / PESO kg | | | |

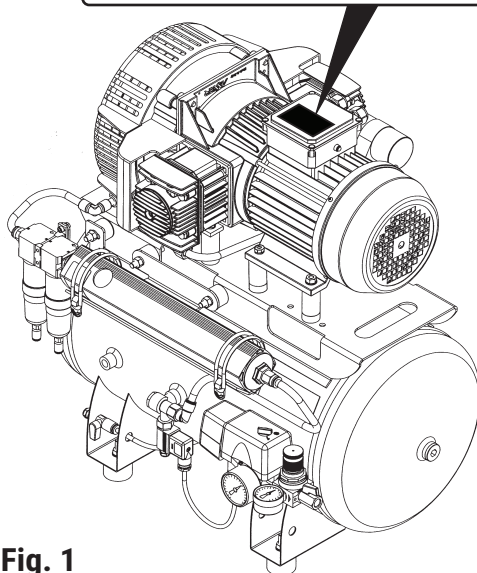

Fig. 1



GENERAL

IMPORTANCE OF THE MANUAL

 **Before using the machine in question, the authorized operators are obliged to read and thoroughly understand this manual in all its parts.**

This instruction manual has been prepared in accordance with the directions provided by the European Directives in order to ensure an easy and correct understanding of the topics covered by the authorized operators operating and maintaining the machine in question.

If, despite the attention being paid by the manufacturer while drafting this document, such operators should not fully understand this text while reading, they are requested to ask the manufacturer for the correct explanations and information in order to avoid incorrect personal interpretations that may jeopardize safety.

Before using the involved machine, the authorized operators are obliged to read and understand all parts of this manual and adhere strictly to the rules herein described in order to assure their own and others' safety, the best performance of the machine and ensure the maximum efficiency and durability of all its components.

This manual shall be available at any time for the authorized operators and shall be well protected and preserved, always close to the machine.

 **This manual should always be available for authorized operators and located in the vicinity of the machine well protected and preserved.**

This manual must compulsorily be delivered together with the machine when it is transferred to another user.





The manufacturer disclaims all liability for injury to persons, animals and/or property caused by ignoring the rules and warnings described in this manual.

This manual reflects the state of the art of technique at the time of the machine marketing and cannot be considered improper just because, according to new experience, it may be updated later on.

In case of loss or damage of the manual request a copy to the manufacturer, specifying the identification data of the document: code, issuance and review.



CONSULTATION NOTES

| SIMBOL | MEANING |
|---|---|
|  | Signal of generic danger: It highlights risks to health and safety of operators and/or risk of damage or malfunction of the machine. |
|  | Signal of generic obligation: It indicates a requirement (obligation to take action). |
|  | Generic prohibition sign: It highlights the prohibition to perform an action. |
|  | Danger Sign EX: It highlights the risk due to explosion. |

STATE "MACHINE OFF"

 Before performing any type of maintenance and/or setting on the machine, disconnect the power supply ensuring that the switch **(18)** is in position "OFF (0)", the plug of the power cable **(15)** is unplugged and placed near the machine and the tank has been drained from residual compressed air by opening the drain valve **(12)**.

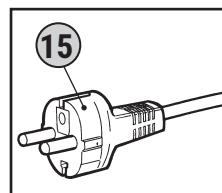

CLINIC 3.40

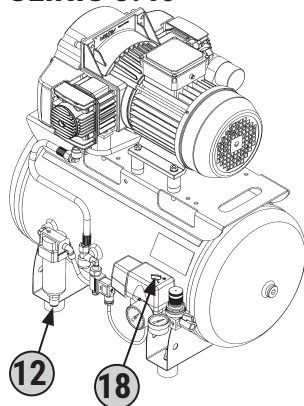

CLINIC DRY 3.40 H

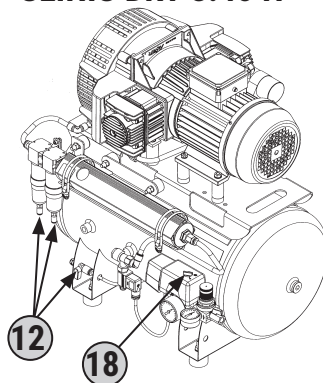

CLINIC DRY 3.40 HS

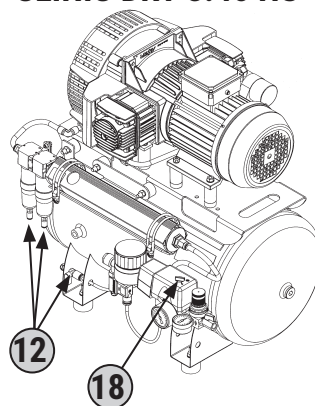



AUTHORIZED OPERATORS



THE OPERATORS ARE AUTHORIZED TO MAKE ON THE MACHINE ONLY SPECIFIC ACTIONS OF THEIR COMPETENCE.

THE AUTHORIZED OPERATORS, BEFORE PERFORMING ANY WORK ON THE MACHINE MUST BE SURE TO BE IN POSSESSION OF FULL PSYCHO-PHYSICAL CAPACITIES, SUCH AS TO ENSURE COMPLIANCE WITH THE SAFETY CONDITIONS.

This technical manual is intended exclusively for Authorized Operators to the use and maintenance of machines according to specific technical and professional skills required for the type of intervention. The symbols below are arranged at the beginning of a chapter and/or paragraph, to indicate which is the operator concerned with the subject matter.

OPERATOR IN CHARGE



It is a professionally trained operator, authorized to perform only the ignition, use, setup, tuning (with the mandatory protection enabled and the machine turned off) and the turning off of the machine and in total respect of the instructions in this manual, equipped with **personal protective equipment (PPD)** specified and occupying the places (see related paragraph).

OPERATOR IN CHARGE FOR HANDLING



It is a professionally trained operator, who has completed 18 years of age, in accordance with the law in the country of use, enabled to the conduct of forklifts, cranes or bridges wagons, to make safe transport, handling and unpacking the machine and/or parts of it, with the **personal protective equipment (PPD)** specified and occupying the places described (see related paragraph).

MECHANICAL/HYDRAULIC/PNEUMATIC MAINTENANCE TECHNICIAN



It is a qualified technician, authorized to perform actions only on the mechanical/hydraulic/pneumatic parts to make adjustments, and maintenance and/or repairs, even with the protections disabled (upon consent of the Supervisor) in strict compliance with the instructions in this manual or other document specifically provided exclusively by the manufacturer, equipped with **personal protective equipment (PPD)** specified and occupying the places described (see related paragraph).



ELECTRICAL MAINTENANCE TECHNICIAN



It is a qualified technician (an electrician in possession of technical and professional qualifications required by the regulations), authorized to perform only work on electrical equipment to make adjustments, and maintenance and/or repairs, even in the presence of voltage and with the protections disabled (upon consent of the Supervisor), **equipped with personal protection devices (PPD)** envisioned and occupying the positions described (see related paragraph).

SAFETY REPRESENTATIVE



It is a qualified engineer appointed by the customer in possession of technical and professional qualifications required by the regulations on safety and health of workers in the workplace.

MANUFACTURER'S TECHNICIAN



It is a qualified technician made available by the manufacturer and/or authorized dealer to perform the required technical assistance, routine work and extraordinary maintenance and/or operations not mentioned in this manual that require specific knowledge of the machine, equipped with **personal protective equipment (PPD)** specified (see related paragraph).



ABBREVIATIONS

Lists some abbreviations used in this book.

- cca. = About
- cap. = Chapter
- PPE = Personal protective equipment
- R = Right
- h = Hours
- EN = European Norm
- Es. = Example
- Fig. = Figure
- max. = Maximum
- min. = Minimum
- min = Minutes
- N. = Number
- page = Page
- par. = Paragraph
- Pos. = Position
- Rif. = Reference
- sec. = Seconds
- L = Left
- TAB. = Table
- see = SEE

ALL RIGHTS RESERVED

The reserved rights related to this instruction manual are in possession of the manufacturer. All information (text, drawings, diagrams, etc.) given here is confidential.

No part of this manual may be reproduced and distributed (in whole or in part) by any means of reproduction (photocopy, microfilm or otherwise) without the written consent of the Manufacturer.

All trademarks are property of their respective owners.



GUARANTEE

- 1) **GUARANTEE DECLARATION:** the Manufacturer gives an undertaking to the End-User to replace, repair or otherwise intervene in the machine, if it has conformity defects that compromise its correct use and operation, but only if such defects are attributable to the actual liability of the Manufacturer. The Manufacturer reserves the right to adopt the optimal solution to restore the conformity of the machine within a reasonable period of time. The guarantee does not cover parts of the Products subject to normal wear and tear and/or deterioration or defects resulting from inappropriate transport.
- 2) **END-USER:** the End-User is the person who buys the machine to use it directly. The End-User who buys the machine as a natural person for purposes that do not fall within the scope of commercial or professional activity is defined as a “consumer”. The End-User is defined as a “professional or company” when the purchase is made by a professional or by a company acting for purposes which fall within the scope of its commercial or professional activity.
- 3) **TERMINALS:** the Manufacturer is liable to the End-User when the lack of conformity occurs within the following terms from the date of purchase:
24 months if the purchase was made by a ‘consumer’ as described in point 2).
12 months if the purchase was made by a “professional or company” as described in point 2).
All End-Users have the right to extend the guarantee (Extended Guarantee) for up to three years from the date of purchase of the machine if they: (a) have registered their purchase on the website www.gentilnair.com within seven days of purchase and (b) have completed the registration form completely and accurately, filling in the required fields with exact, complete and true information and have kept the registration code to be mentioned in the event of problems. Replaced parts or products will remain under guarantee until the original product guarantee expires.
- 4) **VALIDITY:** the guarantee is valid if the End-User notifies the Manufacturer of the conformity defect within 2 months from the date on which he has discovered it, but within the final term indicated in point 3) above. The above report must be accompanied by a regular purchase document (tax receipt or invoice). In the case of an Extended Guarantee, the declaration must also indicate the registration code.
- 5) **FORFEIT:** the guarantee will be void if the purchaser uses the machine improperly and/or not in accordance with the provisions of this “Instruction Manual” provided by the Manufacturer, or if the lack of conformity was caused by inexperience on the part of the purchaser or by chance. The use of the products after the discovery of defects releases the Manufacturer from any guarantee commitment or liability.
- 6) **LIABILITY:** the Manufacturer is released from any liability resulting from any damage sustained by the purchaser, resulting from loss or diminution of production which derives from any lack of conformity.
- 7) **COSTS:** the End-User has the right to the restoration of the conformity of the machine under guarantee without any costs for labour or materials. The shipping methods must be agreed with the authorised dealer or with the Manufacturer. In the event that the non-conformity is only apparent or the complaint arrives after the deadline, the Manufacturer may charge the cost of both transport and any repair that is indicated by the authorised dealer or the Manufacturer.



TECHNICAL DESCRIPTION

NAME OF MODELS

The machine is offered in 3 models. **Tab. 1** shows the model names and specifications that distinguish them.

| MODEL | DESCRIPTION |
|---------------------------|--|
| CLINIC 3.40 | <ul style="list-style-type: none">• Oil-free air compressor with 40 litres tank without dryer. |
| CLINIC DRY 3.40 H | <ul style="list-style-type: none">• Oil free air compressor with 40 litres tank with membrane dryer. |
| CLINIC DRY 3.40 HS | <ul style="list-style-type: none">• Oil-free air compressor with 40 litres tank with membrane dryer and sterile filter |

Tab. 1



NAMES OF PARTS

In Figures are represented the major components that make up the machine.

KEY

- 1) Support feet
- 2) Non-return valve
- 3) Handle
- 4) Cooling fan protection hood
- 5) Pumping unit
- 6) Electric motor
- 7) Restorable circuit breaker
- 8) Electrovalve
- 9) Air intake filter
- 10) Membrane dryer
- 11) Air tank
- 12) Condensate drain
- 13) Sterilization filter
- 14) Tank pressure manometer
- 15) Electric power supply cable with plug
- 16) Safety valve (calibrated at 10.5 bar)
- 17) Pressure switch
- 18) "ON (I) - OFF (0) switch"
- 19) Outlet pressure regulator
- 20) Ball valve - air outlet
- 21) Outlet pressure gauge
- 22) Condensate drain filter

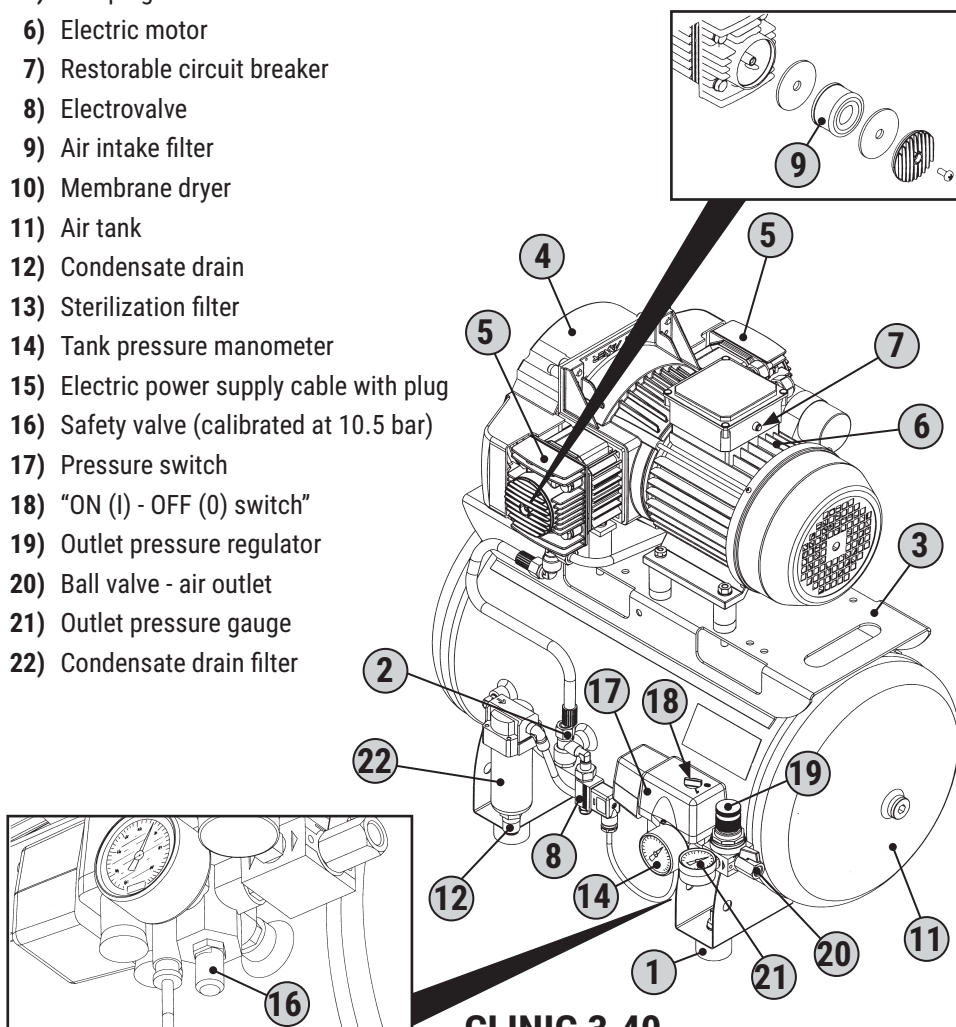

CLINIC 3.40



CLINIC DRY 3.40 H

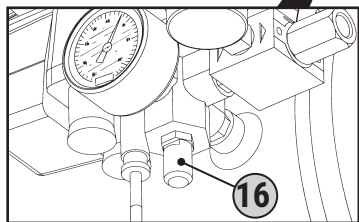
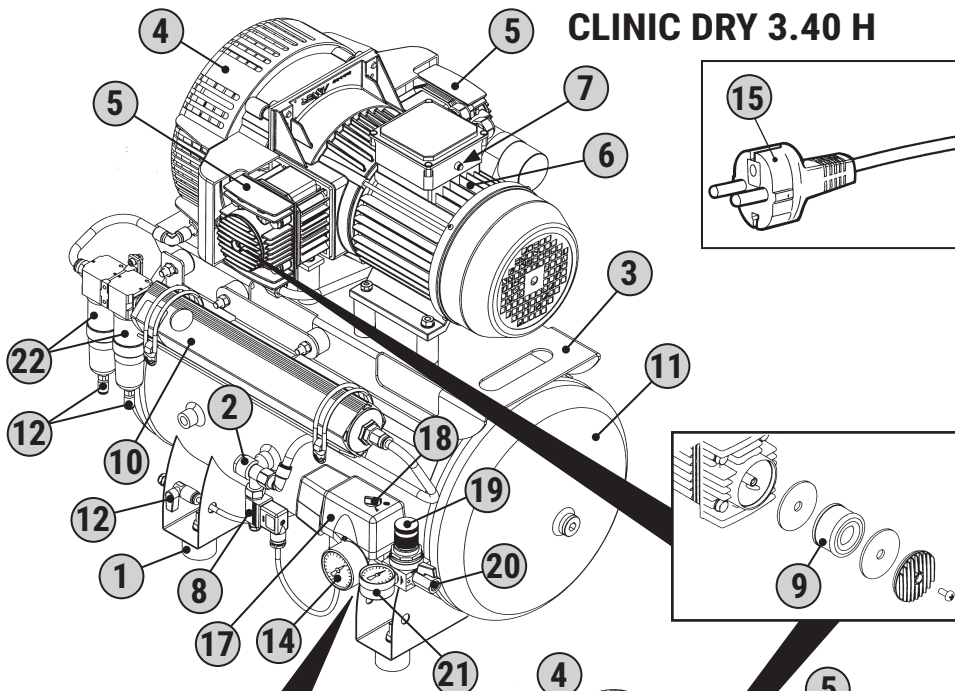

CLINIC DRY 3.40 HS

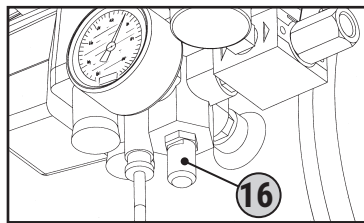
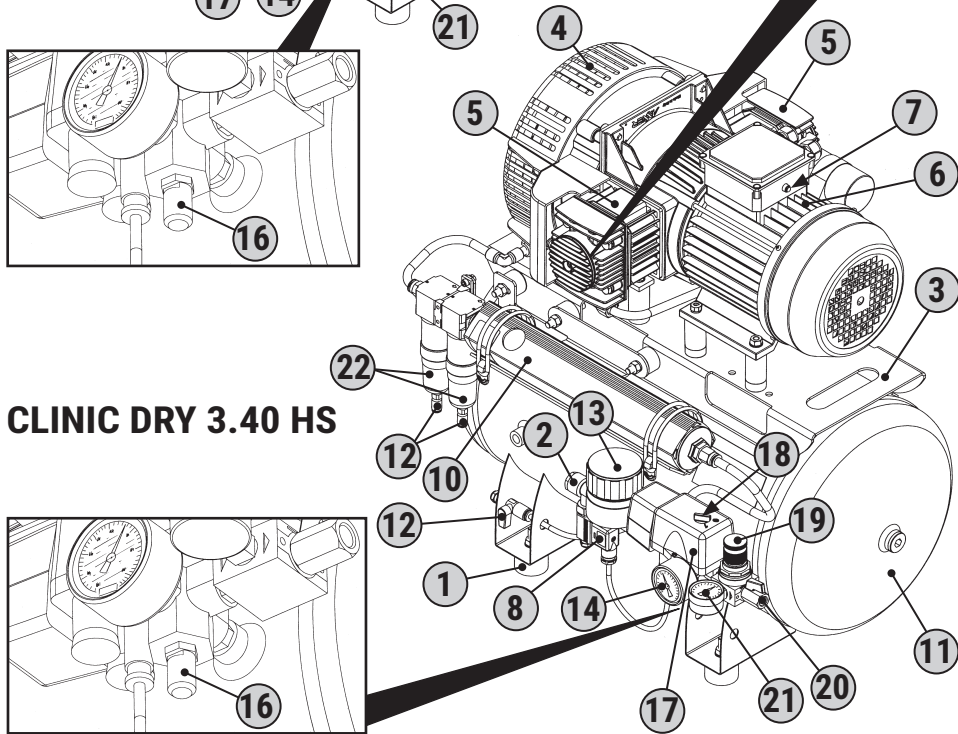



DIMENSIONS OF THE MACHINE

Tab.1 gives the clearance of the machine represented in Fig.1.

CLINIC 3.40

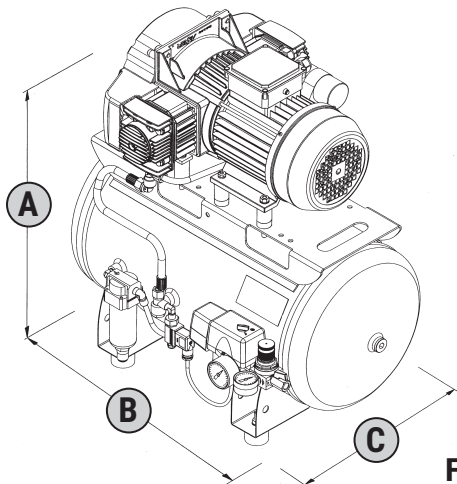

CLINIC DRY 3.40 H

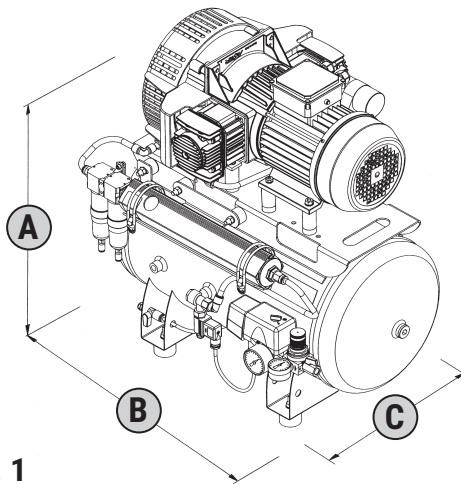
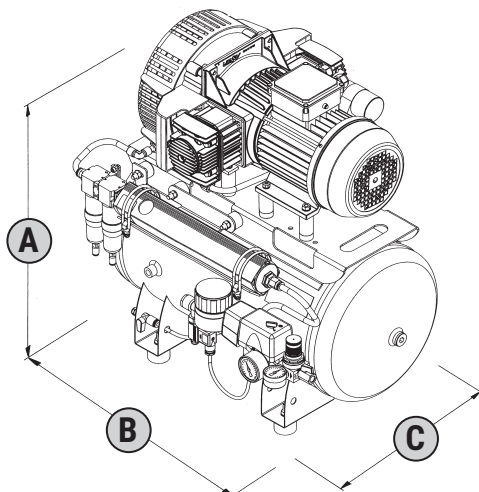

Fig. 1



CLINIC DRY 3.40 HS

| MODELS | A | B | C |
|--------------------|--------|--------|--------|
| CLINIC 3.40 | 653 mm | 652 mm | 455 mm |
| CLINIC DRY 3.40 H | 662 mm | 652 mm | 455 mm |
| CLINIC DRY 3.40 HS | 662 mm | 652 mm | 455 mm |

Tab. 1



TECHNICAL DATA

MACHINE DATA

Tab. 2 shows the technical data which characterize the machine.

| CLINIC 3.40 | | | |
|--------------------------------|---|------------|------------|
| Power supply | 230V/50 Hz | 230V/60 Hz | 110V/60 Hz |
| Electrical Absorption | 8 amper | 11 amper | 22 amper |
| Units served | 2 | 2 | 2 |
| Air delivered (5 bar) (lt/min) | 150 | 170 | 170 |
| Intake air (lt/min) | 240 | 240 | 240 |
| Tank capacity (lt) | 40 | 40 | 40 |
| Motor power (Watt) | 1800 | 2000 | 2000 |
| Noise (db(A)) | 67 | 67 | 67 |
| Weight (Kg) | 39 | 40 | 41 |
| Ambient temperature (°C) | 0-40 | 0-40 | 0-40 |
| Service class | 100% | 100% | 100% |
| Motor rotation direction | The compressor can be used in both directions of rotation | | |

| CLINIC 3.40 H - CLINIC 3.40 HS | | | |
|---------------------------------------|---|------------|------------|
| Power supply | 230V/50 Hz | 230V/60 Hz | 110V/60 Hz |
| Electrical Absorption | 8 amper | 11 amper | 22 amper |
| Units served | 2 | 2 | 2 |
| Air delivered (5 bar) (lt/min) | 130 | 145 | 145 |
| Intake air (lt/min) | 240 | 240 | 240 |
| Tank capacity (lt) | 40 | 40 | 40 |
| Motor power (Watt) | 1800 | 2000 | 2000 |
| Noise (db(A)) | 67 | 67 | 67 |
| Weight (Kg) | 42 | 42 | 43 |
| Ambient temperature (°C) | 0-40 | 0-40 | 0-40 |
| Service class | 100% | 100% | 100% |
| Motor rotation direction | The compressor can be used in both directions of rotation | | |

Tab. 2



INTENDED USE OF THE MACHINE

The machine was designed and built for the use described in **Tab. 1**.

| | |
|------------------------------------|---|
| FIELD OF USE | Dentistry, laboratories or dental cabinets. |
| PLACE OF USE | Places indoors with sufficient lighting, ventilation, air environment having the characteristics referred to under par. "MACHINE DATA" and "PRODUCT USED FOR OPERATION" appropriate to the laws in force in the country of use for safety and health in the workplace. The machine must be placed on a plan that ensures stability in relation to the overall dimensions and weight, respecting the minimum position shown in par. "POSITIONING OF THE MACHINE". WARNING! YOU MUST KEEP THE MACHINE OUT OF REACH OF UNAUTHORIZED PERSONS. |
| INTENDED USE | Compressed air production to operate dental tools. |
| OPERATORS IN CHARGE FOR USE | An authorized operator with the technical and professional capacities meeting the requirements. |

Tab. 1

SOURCE OF ENERGY SUPPLY

Tab. 2 describes the source of energy supply of the machine.

| | |
|----------------------|--|
| ENERGY SOURCE | POWER SUPPLY |
| ELECTRIC | Connection via plug on electrical switchboard. (See Technical Data) |

Tab. 2

PRODUCTS USED FOR THE OPERATION

Tab. 3 shows the product used for the operation.

| PRODUCTS USED FOR THE OPERATION |
|---|
| Ambient air "clean" (good quality) free of pollutants harmful to health |
| Intake air filters (paper) |
| Dryer /filters |

Tab. 3



PHASES OF OPERATION

In **Tab. 4** are listed the steps of operation of the machine (please see the relative paragraphs).

| PHASE | OPERATION |
|-------|--|
| 1 | Turning on the machine. |
| 2 | Adjusting the outlet pressure. |
| 3 | If requested reset the resettable thermal. |
| 4 | Turning off the machine. |

Tab. 4

REASONABLY FORESEEABLE MISUSE

The machine was designed and built for use provided, therefore it is absolutely prohibited any other type of application and use, in order to ensure at all times the safety of the Authorized operators and the efficiency of the machine itself.



RISK OF BURNS DUE TO ACCIDENTAL CONTACT WITH THE PUMPING GROUP AND ELECTRIC MOTOR AND PUMP UNIT. WARNING THERE IS A RESIDUAL RISK.



IT IS COMPULSORY TO INSTALL THE MACHINE IN A PLACE OF USE HAVING THE CHARACTERISTICS INDICATED ON PAR. "INTENDED USE OF THE MACHINE".

IT IS COMPULSORY TO USE THE MACHINE IN THE RESPECT OF THE LEGISLATION IN FORCE IN THE COUNTRY OF USE CONCERNING INTRODUCTIONS (NOISE).

IT IS COMPULSORY TO KEEP THE MACHINE OUT OF REACH OF UNAUTHORIZED PERSONS.



IT IS STRICTLY PROHIBITED THE USE OF THE MACHINE FOR MISUSE AND DIFFERENT USES FROM THE ONE INTENDED BY THE MANUFACTURER.

IT IS ABSOLUTELY FORBIDDEN TO USE THE MACHINE OUTDOORS.

IT IS STRICTLY PROHIBITED THE USE OF AIR TUBES (EXTENSIONS), FITTINGS AND NOT SUITABLE TOOLS AND/OR NOT CONFORM TO THE STANDARDS IN FORCE.

IT IS ABSOLUTELY FORBIDDEN TO LIFT THE MACHINE WITH CRANE AND/OR FORKLIFT.

IT IS ABSOLUTELY FORBIDDEN TO LEAD AIR JETS AGAINST PERSONS AND/OR ANIMALS.

DO NOT CLIMB ONTO THE MACHINE.



IT IS STRICTLY PROHIBITED TO COMMISSION THE MACHINE IN ENVIRONMENTS WITH POTENTIALLY EXPLOSIVE ATMOSPHERE AND/OR IN THE PRESENCE OF COMBUSTIBLE DUSTS (E.G.: WOOD POWDER, FLOUR, SUGARS AND GRAINS).

IT IS ABSOLUTELY FORBIDDEN TO USE THE MACHINE IN AREAS CONTAINING SOLID OR ABRASIVE PARTICLES.

TRANSPORTATION AND HANDLING

TRANSPORTATION OF THE MACHINE



The machine is delivered to the customer through a “specialized transportation company” or by the manufacturer who, through its own personnel and appropriate means, in compliance with the regulations, shall ensure the operations of packaging, lifting, loading, transport and unloading in relation to the type of transport (land, sea or air).



! ALL OPERATIONS OF LIFTING, LOADING, TRANSPORT AND UNLOADING OF THE MACHINE REQUIRE TO BE PERFORMED BY A “SPECIALIZED TRANSPORT COMPANY” OR BY THE MANUFACTURER WITH PERSONNEL AND MEANS SUITABLE FOR USE.

PACKAGING



The machine is fixed to the pallet by straps and covered with a cardboard box. The packaging contains:



- No. 1 compressor
- No. 1 instruction manual

The characteristics of the packaging are indicated in **Tab. 1**.

| Mod. | CLINIC 3.40 | CLINIC DRY 3.40 H | CLINIC DRY 3.40 HS |
|---|-------------|-------------------|--------------------|
| Packaging Weight | 48 Kg | 51 Kg | 52 Kg |
| Pack measurement (machine + bed height) | 68×57×90 cm | 68×57×90 cm | 68×57×90 cm |

Tab. 1



HANDLING OF PACKAGING WITH A FORKLIFT OR TRANSPALLET



IT IS MANDATORY THAT, IN THE RANGE OF HANDLING OPERATIONS, THERE ARE NO PEOPLE, ANIMALS AND/OR THINGS WHOSE SAFETY CAN BE COMPROMISED ACCIDENTALLY.



THE HANDLING OF THE PACKAGE CAN BE PERFORMED ONLY BY THE USE OF A TRANSPALLET OR A FORKLIFT SUITABLE FOR USE.

IT IS MANDATORY, DURING THE LIFTING OPERATIONS, (UP/DOWN), NOT TO MAKE SUDDEN MANOEUVRES AFFECTING STABILITY OF LOAD.

- Insert the forks (2 - Fig. 1) under the pallet (1), keeping them at the centre of the latter.
- Raise the packaging (3) a few centimetres to make sure the load is actually centred in the forks.
- Carefully move the package to the positioning area expected, therefore lowering the load until the full stability is reached.

UNPACKING

After laying the packaging on the ground do the unpacking as follows:

- With a suitable tool, cut the straps (4) taking care not to be affected by the straps as a result.
- Remove the cardboard box.

BE SURE TO DISPOSE THE PACKAGING MATERIAL ACCORDING TO THE DIFFERENT TYPES OF MATERIAL IN THE ABSOLUTE RESPECT OF THE LEGISLATION IN FORCE IN THE COUNTRY OF USE.

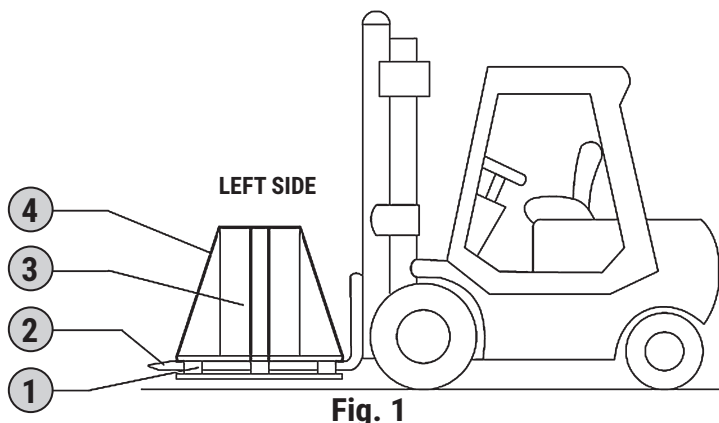



MANUAL HANDLING OF THE MACHINE

! THE MANUAL HANDLING OF THE MACHINE MUST BE DONE BY AT LEAST TWO OPERATORS IN CHARGE, OR USING A SUITABLE MEAN (E.G.: TRANSPALLET), IN ACCORDANCE WITH THE REGULATIONS ON THE “MANUAL HANDLING OF LOADS”, IN ORDER TO AVOID ADVERSE CONDITIONS THAT INVOLVE RISK OF ERGONOMIC INJURIES TO THE BACK.

The machine can be moved manually by two operators in charge, using the handles (1 - Fig. 1) that are attached. Make sure the plug of the power supply cable is disconnected and that the cord is positioned above the tank.

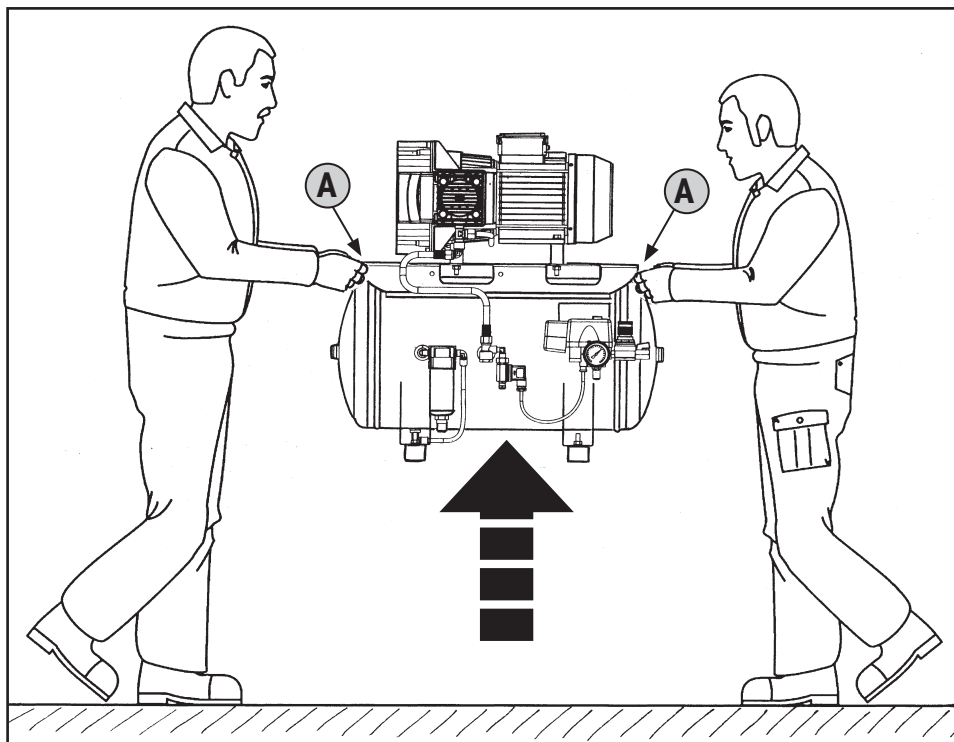

Fig. 1



POSITIONING OF THE MACHINE



The machine must be placed in a workplace with the characteristics described in par. "INTENDED USE OF THE MACHINE", placed on a flat floor that ensures stability in relation to the overall dimensions and to the weight.



IN ORDER TO ENSURE THAT THE AUTHORIZED OPERATORS OCCUPY THE WORK POSITIONS EXPECTED, IT IS MANDATORY TO ENSURE MINIMUM MEASURES OF POSITIONING AS SHOWN IN FIG. 2. IF THE ROOM TEMPERATURE, WHERE THE MACHINE HAS BEEN PLACED, EXCEEDS THE LIMITS SPECIFIED IN PAR. "TECHNICAL SPECIFICATIONS", IT IS COMPULSORY TO INSTALL A SUITABLE ADDITIONAL FAN, AS SHOWN IN FIG. 2.

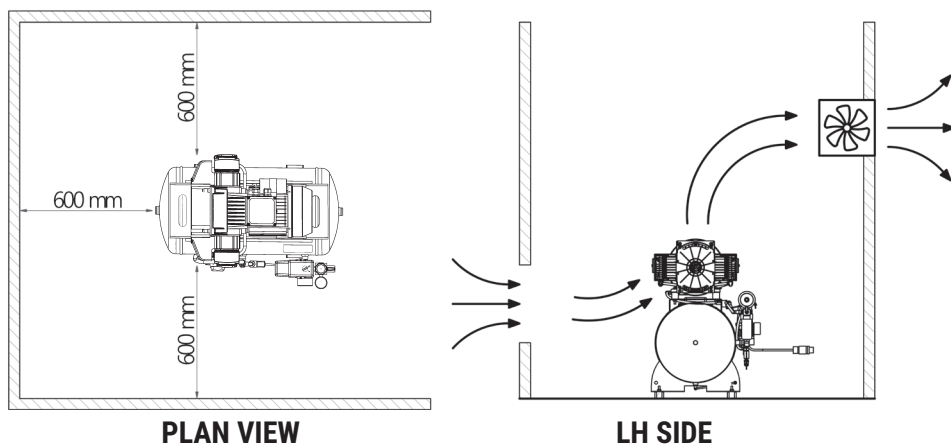

Fig. 2



INSTALLATION

GENERAL WARNINGS

! IT IS COMPULSORY TO COMPLY WITH THE CORRECT PROCEDURES OF ASSEMBLY/DISASSEMBLY AND CONNECTION OF COMPONENTS DESCRIBED IN THIS CHAPTER.

THE MANUAL HANDLING MUST BE IN COMPLIANCE WITH THE REGULATIONS ON THE “MANUAL HANDLING OF LOADS” IN ORDER TO AVOID ADVERSE CONDITIONS THAT INVOLVE RISK OF INJURIES TO THE BACK.

ALL OPERATIONS DESCRIBED BELOW ARE DONE TO PREPARE THE MACHINE READY FOR THE OPERATION.

PNEUMATIC CONNECTION

! THE MANUFACTURER HAS NO LIABILITY FOR INJURY TO PERSONS, ANIMALS AND/OR THINGS, RESULTING FROM FAILURE TO OBSERVE THE WARNINGS DESCRIBED ABOVE.

⊘ IT IS STRICTLY PROHIBITED THE USE OF AIR TUBES (EXTENSIONS), FITTINGS AND TOOLS NOT SUITABLE AND NOT CONFORM TO THE REGULATIONS IN FORCE.

! IT IS COMPULSORY TO USE AIR TUBES (EXTENSIONS), FITTINGS AND TOOLS, ACCORDING TO WHAT IS FORECAST IN THE “INSTRUCTION MANUALS” PROVIDED BY THE MANUFACTURERS.

! The machine must be connected upstream to a pneumatic system for the production sterilized air (by customer) connecting, to the air outlet (20 - Fig. 1), the tube for air inlet of the system equipped with a special fitting.

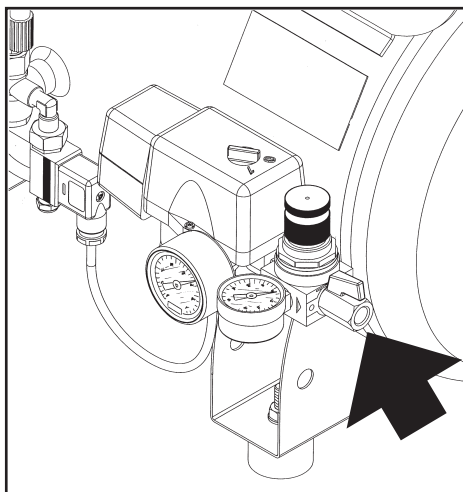

Fig. 1



ELECTRIC CONNECTION



THE MANUFACTURER HAS NO LIABILITY FOR FAILURE OR MALFUNCTIONS OF OPERATION TO THE MACHINE CAUSED BY VOLTAGE DROPS EXCEEDING THE TOLERANCES PROVIDED BY THE DISTRIBUTING BODY ($\pm 10\%$ POWER - FREQUENCY $\pm 2\%$).



THE MAINS TO WHICH THE MACHINE IS CONNECTED MUST BE IN ACCORDANCE WITH THE REQUIREMENTS OF THE LAWS OF THE COUNTRY OF USE, MEET THE SPECIFICATIONS CONTAINED IN PAR. "MACHINE DATA" AND BE PROVIDED WITH A SUITABLE GROUNDING SYSTEM.

IT IS COMPULSORY TO INSTALL UPSTREAM OF THE POWER SUPPLY LINE AN ELECTRIC CUTTING DEVICE WITH A SUITABLE DISCONNECTING PROTECTION COORDINATED WITH THE GROUNDING PLANT.

ANY TYPE OF ELECTRIC MATERIAL USED FOR THE CONNECTION MUST BE SUITABLE FOR USE, MARKED "CE" IF SUBJECT TO LOW VOLTAGE DIRECTIVE 2006/95/EC AND COMPLYING WITH THE REQUIREMENTS OF THE REGULATIONS IN FORCE IN THE COUNTRY OF USE OF THE MACHINE.

IF NECESSARY, IT IS COMPULSORY TO CONNECT THE MACHINE ONLY TO GENERATORS OF ELECTRICITY WITH A POWER GREATER THAN THE POWER SUPPLY INSTALLED, TO SUPPORT THE ABSORPTION CURRENT UPON STARTUP.

FAILURE TO FOLLOW THE WARNINGS ABOVE MAY CAUSE IRREVERSIBLE DAMAGE TO THE ELECTRIC EQUIPMENT OF THE MACHINE AND THE SUBSEQUENT VOID OF THE WARRANTY.



The machine can be connected to the mains by plugging the power cord (15) into the power outlet (by the Customer).

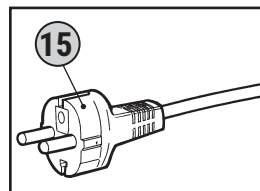



SAFETY

SAFETY DEVICES

The Safety Devices adopted are as follows (for the references on the drawings, please see the pages down):

| REF. | DESCRIPTION | FUNCTION |
|------|-------------------------------------|--|
| 1 | Cooling fan protection hood. | It is a fixed guard that consists of a grid of plastic material fixed with screws at the base of the twin cylinder pumping unit. It prevents accidental contact with the moving cooling fan. |
| 2 | Resettable thermal. | It is a thermal protection installed on the electrical system, which stops the electric motor in case of current overload and/or short circuit. Recovery can be done through the appropriate button. |
| 3 | Tank pressure gauge. | It is a measuring device installed on the tank of the machine. It shows the air pressure inside the tank (0 ÷ 10 bar). |
| 4 | Safety valve. | It is a certified safety valve (set at 10.5 bar), installed in the pneumatic system under the pressure switch. It is used to discharge the overpressure of the system if the pressure switch, for any problems, does not function. The intervention of the safety valve forces the operator to turn off the machine and request the assistance of the maintenance personnel (see par. "INTERVENTION OF THE SAFETY VALVE"). |
| 5 | Pressure switch. | It is an electro-pneumatic device (set at min. 8 bar, max. 10 bar) fitted onto the pneumatic plant. It is used to control the automatic start of the machine when the pressure drops to 8 bars and the automatic stop when the pressure reaches 10 bars. |

 **IT IS COMPULSORY TO CONSTANTLY CHECK THE GOOD FUNCTIONING AND THE EFFICIENCY OF ALL SAFETY DEVICES IN THIS MACHINE.**

IT IS COMPULSORY TO REPLACE ANY SAFETY DEVICES MALFUNCTIONING AND/OR DAMAGED.



⊘ IT IS FORBIDDEN TO MANIPULATE, EXCLUDE, REMOVE AND/OR REPLACE ANY SAFETY DEVICE IN THIS MACHINE.

IT IS ABSOLUTELY FORBIDDEN TO REPLACE ANY SAFETY DEVICE OR COMPONENT WITH NON ORIGINAL SPARE PARTS.

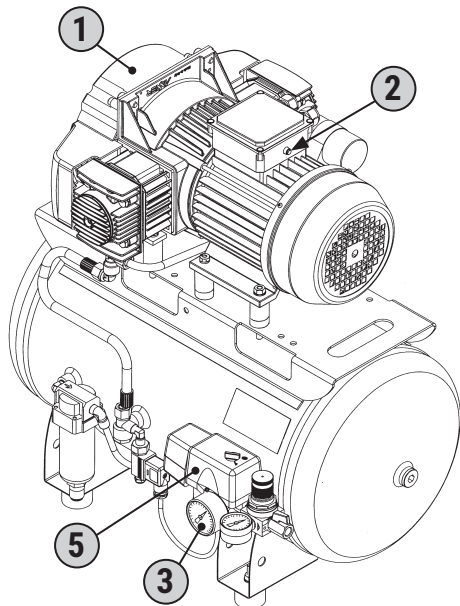

CLINIC 3.40

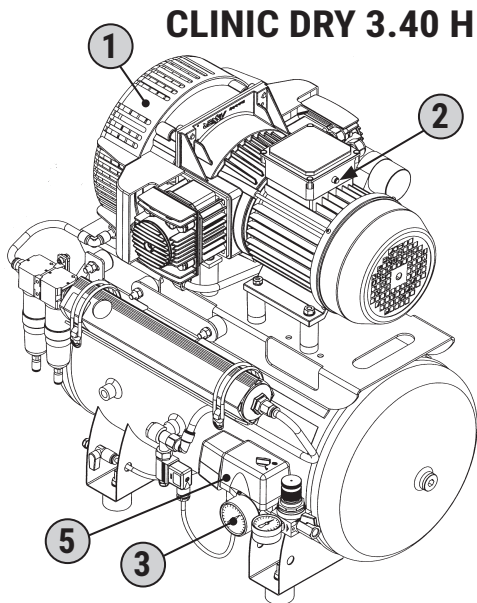
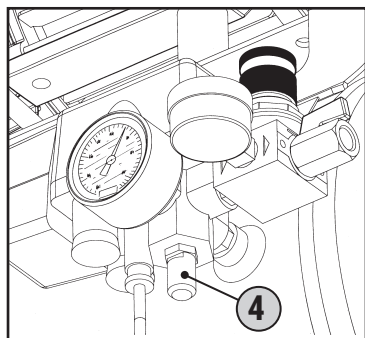

CLINIC DRY 3.40 H

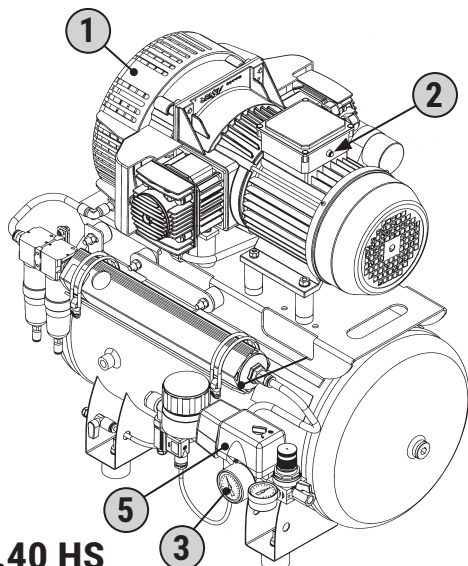



CLINIC DRY 3.40 HS



PERSONAL PROTECTIVE EQUIPMENT (PPD)

The use of personal protective equipment (PPD) is mandatory, in accordance with the legislation on safety and health in the workplace regulations of the country of use of the machine.

| SEGN | PPE REQUIRED | TYPE OF APPLICATION |
|--|---|---|
|  | Protection of hands (protective gloves against thermal hazards) | During handling, installation, operation and maintenance. |
|  | Protection of feet (shoes with reinforced toe) | |

Tab. 1

 **IT IS COMPULSORY TO USE THE PPD SUGGESTED BY THE MANUFACTURER (SEE Tab. 1).**

RESIDUAL RISKS

The authorized operator must remark that, although the manufacturer has taken every precaution technically possible to make the machine safe, in order not to compromise the functionality and productivity of the machine, there are still two potential residual risks described in **Tab. 2** and **3**.

| | |
|------------------------------------|---|
| RESIDUAL RISK N. 1 | DANGER OF BURNS IN THE PUMPING GROUP AND ELECTRIC MOTOR |
| SEVERITY OF THE INJURY | Light, normally reversible injuries. |
| EXPOSURE | If the operator decides to perform a voluntary improper action, forbidden and not reasonably foreseeable. |
| PROBABILITY | Low and accidental. |
| STAGE WHERE THERE IS A RISK | During use and operation. |
| MEASURES TAKEN | Safety signs. Compulsory use of personal protective equipment (PPD) and/or wait for the cooling of the machine. |

Tab. 2



| | |
|------------------------------------|---|
| RESIDUAL RISK N. 2 | DANGER OF CRUSHING FOOT DUE TO ACCIDENTAL FALL FROM THE MACHINE |
| SEVERITY OF THE INJURY | Serious injuries usually reversible. |
| EXPOSURE | If the operator decides to perform a voluntary improper action, forbidden and not reasonably foreseeable. |
| PROBABILITY | Low. |
| STAGE WHERE THERE IS A RISK | During handling and placement. |
| MEASURES TAKEN | Procedures for handling of the packaging and machine (see chap. "TRANSPORTATION AND HANDLING"). |

Tab. 3

SAFETY SIGNS

The Safety signs used are constituted by an adhesive label, applied externally to the machine (Fig. 1).

 **IT IS ABSOLUTELY FORBIDDEN TO REMOVE AND/OR DAMAGE THE SAFETY SIGNS APPLIED TO THE MACHINE.**

 **IT IS COMPULSORY TO KEEP WELL CLEAN THE SIGNS IN ORDER TO ENSURE A GOOD VISIBILITY.**

IT IS COMPULSORY TO REPLACE THE SAFETY SIGNS DETERIORATED, BY REQUESTING THEM TO THE MANUFACTURER AND/OR AUTHORIZED DEALER.

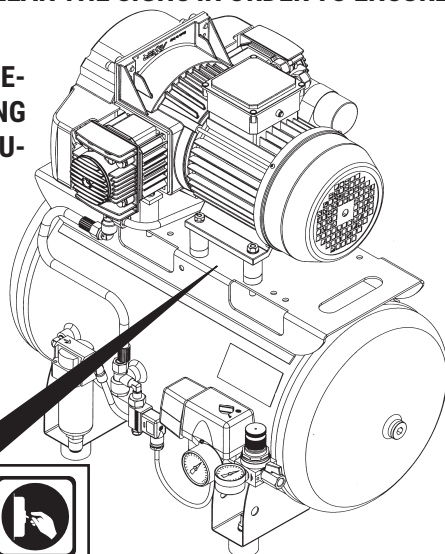

Fig. 1



| SIGN | MEANING/PRESCRIPTION | SIGN | MEANING/PRESCRIPTION |
|------|--|------|---|
| | DANGER: Electric Current | | REQUIREMENT: Read the instruction manual |
| | DANGER: Automatic start | | |
| | DANGER: Dangerous Temperatures | | REQUIREMENT: Turn off the machine before carrying out maintenance |

USE AND OPERATION

PLACES OCCUPIED BY AUTHORIZED OPERATORS

The Authorized operators, depending on the type of manual intervention required, must take the places shown in Fig. 1.

THE AUTHORIZED OPERATORS ACCORDING TO THE PLACE OCCUPIED, ARE OBLIGED TO PERFORM THE REQUIRED ACTIONS DESCRIBED IN THE RELATED SECTIONS.

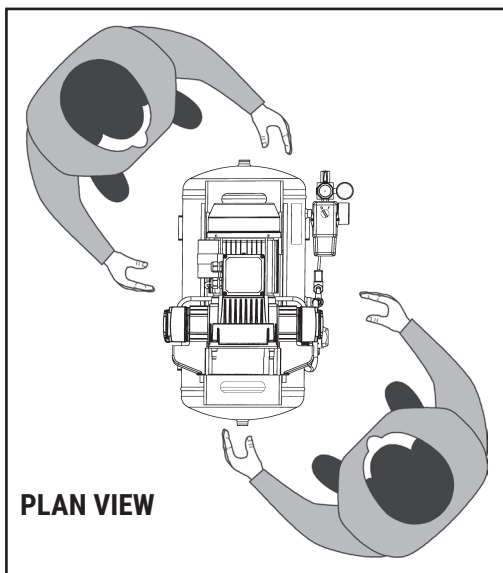

Fig. 1

| AUTHORIZED OPERATORS | PLACE | DESCRIPTION OF INTERVENTION |
|----------------------|-------|---|
| | ALL | With the consent of the Supervisor, execute on the machine lifting operations, maintenance operations, handling and use of the machine. |



PRESSURE SWITCH

In **Fig. 2** is represented the control device to which the authorized operator must refer for the command and control of the machine.

| REF. | NAME | FUNCTION |
|------|--------------------------------------|---|
| 1 | Air outlet. | ¼" G hole for air connection. |
| 2 | Tank pressure gauge. | It shows the outlet air pressure set through the regulator. |
| 3 | Pressure switch. | It is an electro-pneumatic device (set at min. 8 bar max. 10 bar) fitted onto the pneumatic plant. It is used to control the automatic start of the machine when the pressure drops to 8 bar and the automatic stop when the pressure reaches 10 bar. |
| 4 | Interruttore "ON (I)-OFF (0)" | Pos. "ON (I)": Turns on the machine; Pos. "OFF (0)": Turns off the machine. |
| 5 | Safety valve. | It is a certified safety valve (set at 10.5 bar), installed in the pneumatic system under the pressure switch. It is used to discharge the overpressure in the system if the pressure switch, for any problems, does not function. The intervention of the safety valve forces the operator to turn off the machine and request the assistance of the maintenance technicians. |

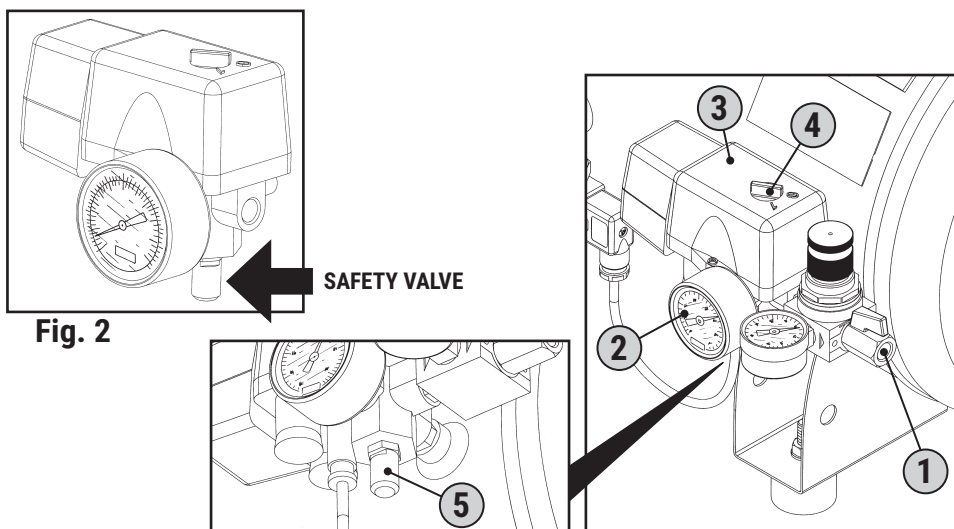

Fig. 2



PRIOR TO IGNITION



BEFORE TURNING ON THE MACHINE THE OPERATOR IN CHARGE MUST MAKE THE CHECKS INDICATED IN TAB. 1.



| No. | CONTROL |
|-----|--|
| 1 | Make sure that no unauthorized persons are near the machine. |
| 2 | Make sure the machine is properly positioned. |
| 3 | Make sure all connections are properly made. |
| 4 | Ensure that the switch (18) is in pos. "OFF (0)". |
| 5 | Make sure the condensate drain valve is closed (12). |
| 6 | Use the Personal protective equipment (PPE) required. |
| 7 | Make sure you have read and understood all parts of this "Instruction Manual". |
| 8 | Make sure that after last use routine maintenance has been made. |

Tab. 1

TURNING ON THE MACHINE



THE AUTHORIZED OPERATORS CAN TURN THE MACHINE ON ONLY AFTER THEY HAVE PERFORMED AS A COMPULSORY OPERATION, THE CONTROLS DESCRIBED IN THE CONTROLS TABLE BEFORE USING THE MACHINE IN



QUESTION IT IS COMPULSORY THAT THE AUTHORIZED OPERATORS READ AND THOROUGHLY UNDERSTAND IN ALL PARTS THIS MANUAL. IT IS COMPULSORY TO KEEP THE MACHINE OUT OF REACH OF UNAUTHORIZED PERSONS.



IT IS FORBIDDEN TO THE AUTHORIZED OPERATORS TO LEAVE THE MACHINE WITHOUT SUPERVISION DURING THE MAINTENANCE WORKS.

THE MANUFACTURER HAS NO LIABILITY FOR INJURIES TO PERSONS, ANIMALS AND/OR THINGS CAUSED BY THE INOBSERVANCE OF THE RULES AND INFORMATION DESCRIBED HEREIN.

Turn on the machine by moving the switch (18) in pos. "ON (I)" (the machine runs up to the max. operating pressure at 10 bar and then stops automatically).

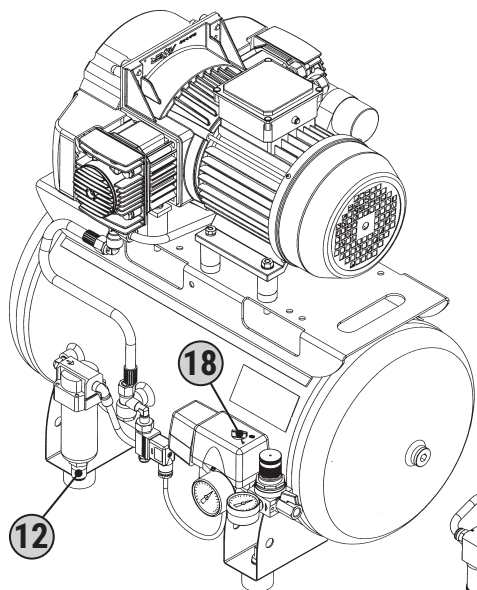

CLINIC 3.40

CLINIC DRY 3.40 H

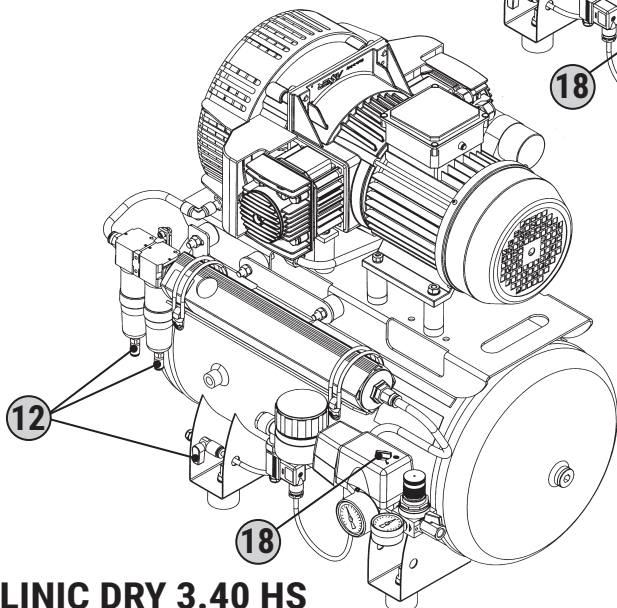
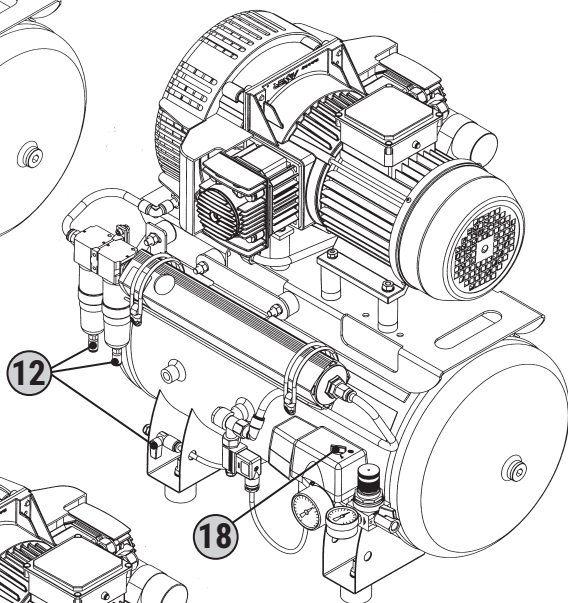

CLINIC DRY 3.40 HS



RESETTABLE THERMAL

 **If there is an overload and/or a short circuit in the electrical system of the machine, the overload protection intervenes stopping the electric motor.**



The reset will occur automatically when the temperature returns within the parameters preset by the manufacturer:

- Set the switch (18) in pos. "OFF (0)".
- Press the button of the resettable thermal (7).
- Before restarting the machine wait a few minutes.

 **IF AFTER PERFORMING THE RESET THE MACHINE WILL NOT RESTART, THE OPERATOR IS REQUIRED TO OBTAIN THE INTERVENTION OF MAINTENANCE TECHNICIANS AND/OR THE AUTHORIZED DEALER.**

TURNING OFF THE MACHINE

 **At the end of the work cycle perform the turning off of the machine as follows:**

-  • Set the switch (18) in pos. "OFF (0)".
-  • Unplug the power cord (15) from the socket and place it next to the machine.
-  • Only in case of work cycle end perform the condensate discharge from the tank, acting on the condensate drain valve (12).

EMERGENCY STOP

 **The Emergency Stop of the machine can be done by bringing in pos. "OFF (0)" the switch (18). To avoid situations of imminent danger, the Authorized**

 **Operators are obliged to perform the following operations:**

| | |
|----------|---|
| 1 | RUN IMMEDIATELY THE TURNING OFF OF THE MACHINE AS DESCRIBED IN PAR. "TURNING OFF THE MACHINE". |
| 2 | REPORT IMMEDIATELY THE EMERGENCY TO THE SUPERVISOR IN CHARGE. |

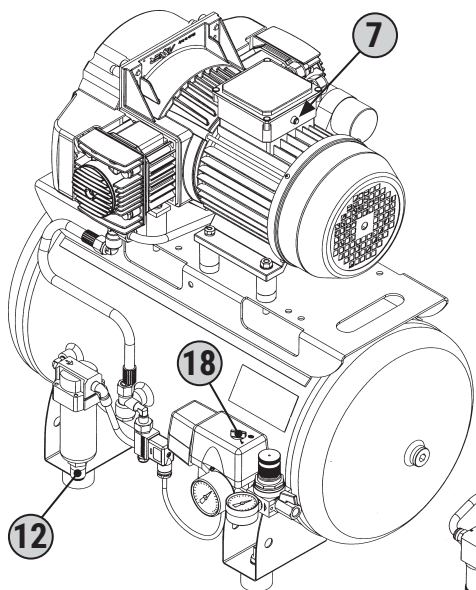

CLINIC 3.40

CLINIC DRY 3.40 H

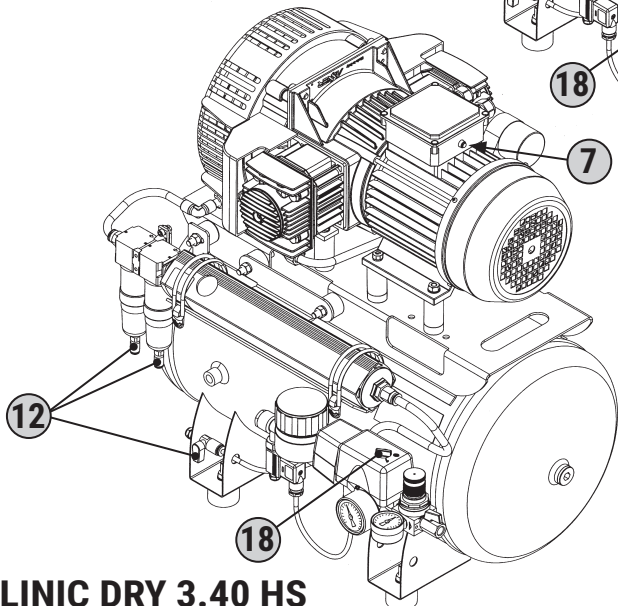
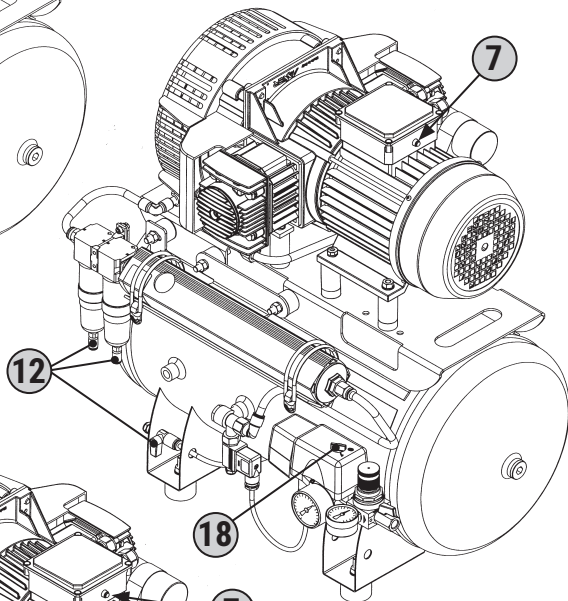

CLINIC DRY 3.40 HS



ACTIVATION AFTER AN EMERGENCY STOP



Only after removing the cause of the emergency and having carefully evaluated that the decision has not caused any damage and/or problems to the machine, with the consent of the Supervisor in charge restore the machine as described in the following paragraph:



the machine as described in the following paragraph:

- Set the switch **(18)** in pos. "OFF (0)".
- If necessary, repeat the operations described in par. "TURNING ON THE MACHINE".

INTERVENTION ON THE SAFETY VALVE



In the event of a malfunction of the pressure switch and the pressure inside the tank exceeds 10,5 bar, the safety valve operates mechanically by opening for venting outside the compressed air and return the pressure to the safety value.



UPON THE INTERVENTION OF THE SAFETY VALVE IT IS COMPULSORY TO TURN OFF THE MACHINE, NOTIFY THE SUPERVISOR AND REQUEST ASSISTANCE OF MAINTENANCE TECHNICIANS OR AUTHORIZED DEALER TO MAKE THE CONTROL OF PRESSURE SWITCH.

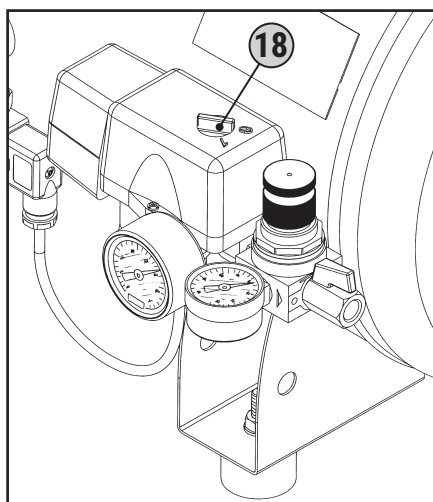



TROUBLESHOOTING



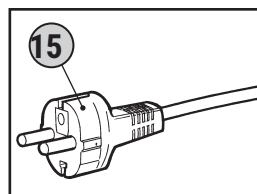
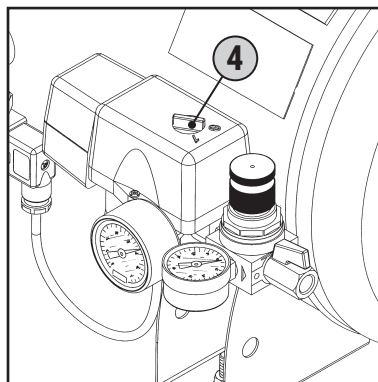

 **FAILURE TO FOLLOW THE PROCEDURES CONTAINED IN THIS PARAGRAPH MAY CAUSE A MALFUNCTION OF THE MACHINE AND/OR UNDERMINE THE SAFETY OF THE SAME.**

| PROBLEM | CAUSE | SOLUTIONS |
|---|--|--|
| The machine does not turn or stops and does not restart. | No electricity. | <ul style="list-style-type: none"> • Check that the switch (18) is in pos. "ON (I)". • Check that the power cord plug (15) is working properly and inserted into the socket. • Check that any extension cords used and the current outlet are operational. • Check that the switch of the main power supply is functioning and in pos. "ON (I)". |
| The machine does not turn or stops and does not restart. | Intervention of the resettable thermal due to current overload and/or short circuit. | <ul style="list-style-type: none"> • Follow the procedure described in par. "RESETTABLE THERMAL". |
| The machine often starts again without the pneumatic plant is operating. | Air leaks from the pipe or its pneumatic plant. | <ul style="list-style-type: none"> • Check that the pneumatic system is not damaged. • Check the integrity of the pipe connections and air system. |





| PROBLEM | CAUSE | SOLUTIONS |
|--|-------------------------------|---|
| Intervention of the safety valve. | Faulty pressure switch. | See the maintenance technicians or contact an Authorized Reseller.    |
| Air leak from the valve of the pressure switch with machine stopped. | Check valve is dirty or worn. | |
| The machine vibrates and/or makes a lot of noise. | Mechanical failure. | |
| Frequent starts and low efficiency. | Dirty air filters. | |

MAINTENANCE

 This is the set of activities designed to maintain the conditions of use and operation of the machine, through various types of intervention (adjustments, visual inspection, recovery levels, etc.) performed by the maintenance technician or by the manufacturer's technician at the frequency forecast.



 THE AUTHORIZED OPERATORS SHOULD PERFORM ONLY THE MAINTENANCE WORKS REQUIRED IN ACCORDANCE WITH THEIR SPECIFIC PROFESSIONAL COMPETENCE AND UPON CONSENT OF THE SUPERVISOR IN CHARGE.

 IT IS FORBIDDEN TO AUTHORIZED OPERATORS TO LEAVE THE MACHINE WITHOUT SUPERVISION DURING THE MAINTENANCE WORKS. THEY SHOULD ALSO PROTECT THE PLACE OF WORK WITH A WHITE/RED CHAIN AND EXPOSE ADEQUATE NOTICE OF DANGER AND PROHIBITION FOR WORKS IN PROGRESS.

| | | |
|--|-----------------------|------------------|
|  | POINT OF INTERVENTION | TANK |
| | TYPE OF INTERVENTION | CONDENSATE DRAIN |



EVERY WEEK



At the end of the workday, run the condensate drain of the tank, following the steps below:



- Place under the condensate drain valve, a collection container fit for use.
- Slowly open the valve of condensate drain (12) and wait for a complete exit of compressed air and condensate.
- Close the drain valve.
- Indicate the action on the maintenance card.



YOU MUST DISPOSE OF THE CONDENSATION LIQUID IN COMPLIANCE WITH THE REGULATIONS IN FORCE IN THE COUNTRY OF USE.

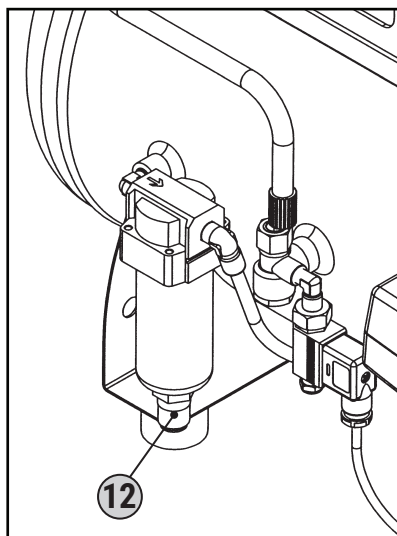

CLINIC 3.40

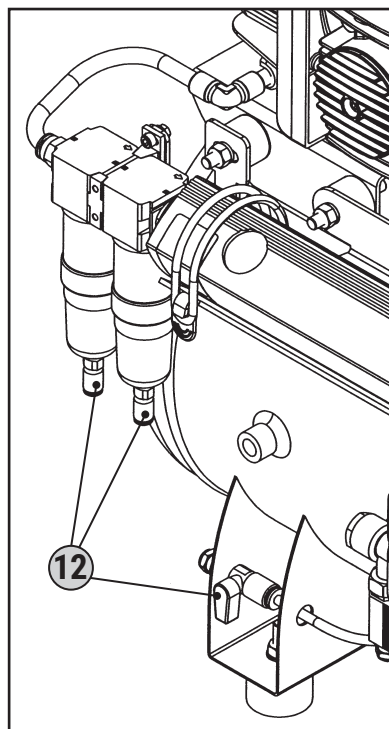

**CLINIC DRY 3.40 H
CLINIC DRY 3.40 HS**



EVERY MONTH



Proceed as follows:

- Unscrew the screw (1).



- Remove the cover (2).

- Remove the filter (3) and clean it with compressed air.



REPLACE THE FILTER IN CASE OF EVIDENT WEAR.

- After placing back the filter, replace the cover properly.
- Indicate the action on the maintenance card.



YOU MUST DISPOSE OF THE FILTERS REPLACED IN COMPLIANCE WITH THE REGULATIONS IN FORCE IN THE COUNTRY OF USE.

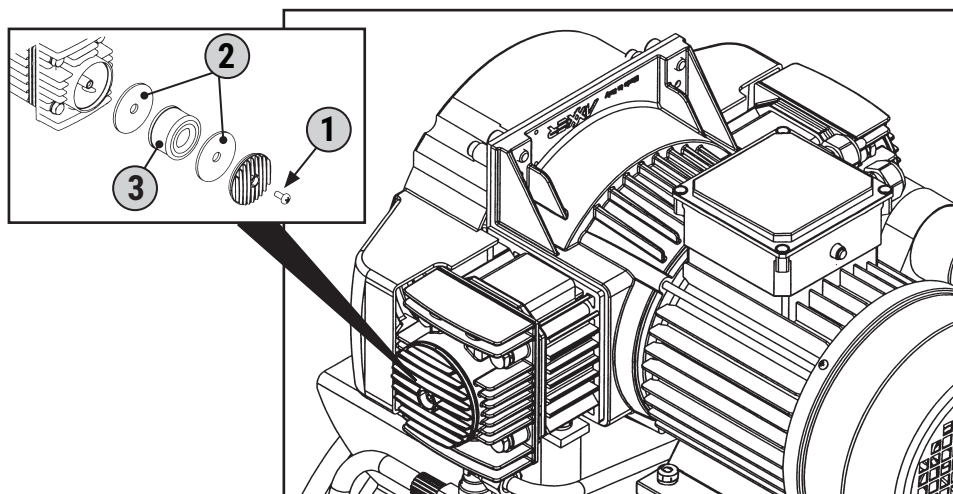

| | | |
|--|------------------------------|--------------------------|
| | POINT OF INTERVENTION | COALESCING FILTER |
| | TYPE OF INTERVENTION | REPLACE |



AFM 30 CARTRIDGE REPLACEMENT

- Press the lever down **(A)**, turn of 45° the cup **(B)** and remove it from the cover **(C)**.
- Unscrew the filter **(D)**.
- Screw in the new filter.
- Insert the cup in the top cover and turn 45°.

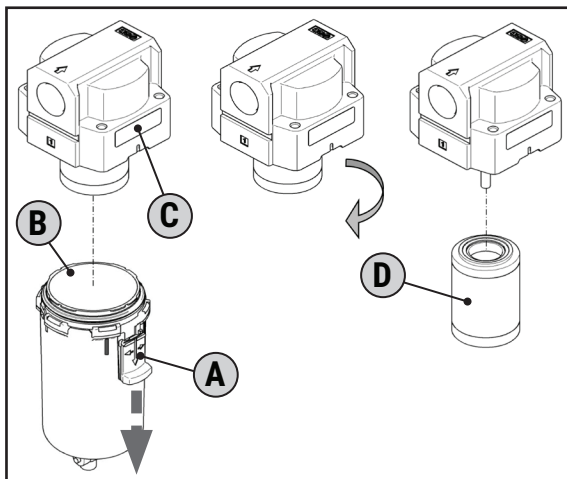

AF 30 CARTRIDGE REPLACEMENT

- Press the lever down **(E)**, turn of 45° the cup **(F)** and remove it from the cover **(G)**.
- Remove the assembled component **(H)**.
- Unscrew the lower deflector **(I)**.
- Replace the filter cartridge **(L)**.
- Screw the lower deflector back on.
- Insert the assembled component in the cup.
- Insert the cup in the top cover top and turn of 45°.

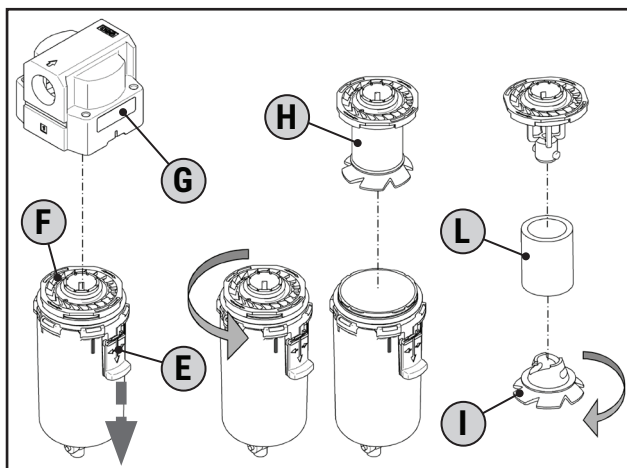



STERILE FILTER REPLACEMENT

- Unscrew the cover by hand (A).
- Remove the filter (B).
- Insert the new filter.
- Screw the cover up until it reaches the mechanic stop.
- Report the intervention on the maintenance sheet.

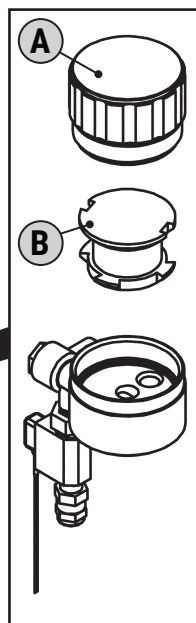
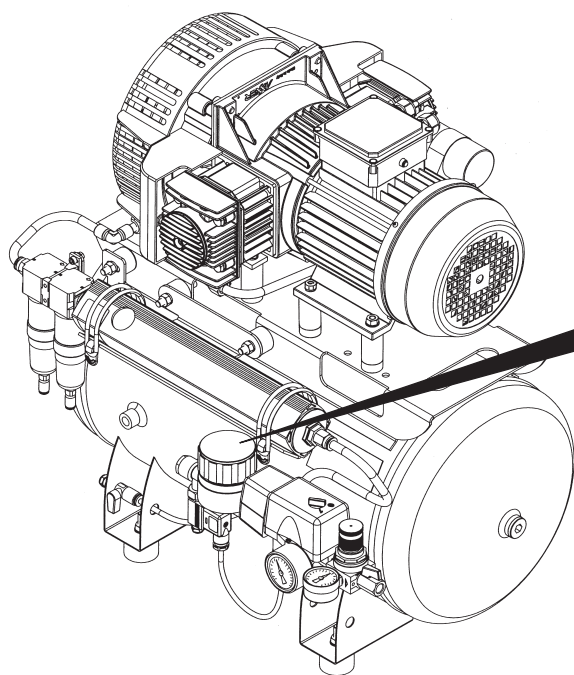



EXTRAORDINARY MAINTENANCE



This is the set of activities designed to maintain the conditions of use and operation of the machine, through various types of intervention (adjustments, changes, etc.) performed by qualified technicians in the event of failure or wear.



FOR ANY INTERVENTION OF EXTRAORDINARY MAINTENANCE IT IS COMPULSORY TO REQUIRE THE TECHNICAL ASSISTANCE TO THE MANUFACTURER OR AUTHORIZED DEALER.

DECOMMISSIONING

STORAGE



In the event that the machine should be stored for some time, you must place it in a safe environment, with a proper degree of temperature, humidity and protected from dust.



DEMOLITION



Upon demolition of the machine, strictly follow the requirements in force in the country of demolition.



Proceed to the differentiation of the parts that make up the machine according to the different types of construction materials (plastics, copper, iron, etc. ...).



These products must be considered pollutants and hazardous charging licensed contractors and disposed of by appointing specialized companies for different types of products.



ALL PARTS OF THE MACHINE MUST BE IDENTIFIED ACCORDING TO THE DEFINITIONS OF "CER CODES" (EUROPEAN WASTE CATALOGUE) AND DISPOSED OF BY INSTRUCTING AUTHORIZED AND SPECIALIZED COMPANIES, IN STRICT COMPLIANCE WITH THE REGULATIONS IN FORCE IN THE COUNTRY OF DEMOLITION OF THE MACHINE.



WASTES OF ELECTRICAL AND ELECTRONIC EQUIPMENT (RAEE) MUST BE DISPOSED OF IN STRICT COMPLIANCE WITH THE REGULATIONS IN FORCE IN THE COUNTRY FOR THE DEMOLITION OF THE MACHINE.



SPARE PARTS

 **GENUINE PARTS FOR ANY SUBSTITUTIONS MUST BE REQUIRED ONLY TO THE MANUFACTURER.**

 **IT IS STRICTLY PROHIBITED THE USE OF NON ORIGINAL SPARE PARTS.**

ATTACHMENTS

DRYER/FILTER TECHNICAL SHEETS

The following pages will give the technical sheets relative to the dryer/filter.

DRYTEC TECHNICAL SHEET

The DRY TEC membrane dryer collects all of the following parts in a unique block:

- **Filtering element ÷ condensate separator**, housed in the lower compressed air input head. Its function is to separate the condensate liquid phase and then convey just the water vapour phase towards the cores of the hollow fibre membranes.
- **Anti-pulse device**: this is intelligently housed inside the filter itself and dampens the pulse flow pertinent to the movement of the piston compressors, thus protecting the fibres from undesirable stress.
- **Automatic condensate drain**: no compromise is allowed: it is a real float drain that operates depending on the rising level of condensate and not of a partial device that can only drain at the end of pumping.
- **Core dehydrator**: this is made up from a bundle of hollow fibre membranes, whose characteristic is that of distributing, i.e. transferring the humidity towards the outside, through a porous wall characterised by a so-called selective molecular size, which allows migration just of the water vapour molecule, while the molecules of nitrogen and oxygen making up the air flow remain inside the capillary tube.
- **Regeneration nozzle cut-off**: in order to favour the extraction of the humidity “pumped” through the porous wall, a percentage (~10 %) of dry air is expanded through a nozzle, which makes this regeneration current flow in backflow mode on the external side of the intertwined fibre membranes. Flexible and rational: depending on the size of the compressor, the nozzle can be changed so that a unique membrane covers the entire range of flow rates (nominally from 100 and 150 NI/min, which can be optimised depending on customer requirements).



- **Anti-bacterial filter (option):** the output head is already set-up to house an anti-septic filtering element. It is offered as an optional so as not to increase the purchase cost of the equipment is not needed, so as to satisfy the more demanding customer without further transformations. The components of this sterile element are in compliance with that governed by the FDA Standard (Food and Drug Administration) and can be sterilised in autoclave according to conventional criteria.

DRY TEC DRYING SYSTEM - DATA SHEET

| | |
|---------------|--|
| FLUID: | Compressed air generated by non-lubricated compressor |
| | Saturated with water vapour |
| | No pulses |

SERVICE:..... **continuous, 24/24 hours**

INPUT COMPRESSED AIR FLOW RATE: **145 sl/min.**

OUTPUT COMPRESSED AIR USEFUL FLOW RATE:..... **123 sl/min.**

COMPRESSED AIR INPUT TEMPERATURE: **from +2°C to +50°C**

SUPPLY RATED PRESSURE: **7 bar**

DRYER DEW POINT AT ROOM TEMPERATURE OF 25°C: **-19,4°C**

PROJECT TEMPERATURE:..... **from +2°C to +50°C**

PROJECT PRESSURE: **max 10 bar**

INSTALLATION:..... **internal**

QUALITY CONSTRUCTION CODE: **ISO9001:2008**



ETHAFILTER s.r.l.
Via Dell'Artigianato, 16/18
I-36050 Sovizzo (Vicenza) Italia
Tel. + 39 / 0444 376402
Fax +39 / 0444 376415
e-mail: ethafilter@ethafilter.com

CERTIFICATE of CONFORMITY STERILE FILTER ELEMENT

Model: EDT 5635SR

These aseptic class filter elements are produced to the highest quality standards to ensure the requirements of sterile degree in compressed air and gas feed.

Materials of construction are as follows:

| | |
|-----------------------------------|--|
| Endcaps: | AISI 304 grade stainless steel or FDA allowed white sintetic material |
| Inner and outer cylinder: | expanded AISI 304 grade stainless steel |
| High Efficiency Filtration layer: | "depth sandwich" of borosilicate glass micro fibre |
| Sealant: | white silicone compound, selected for resistance to high temperature, composition in accordance with F.D.A. recommendations. |
| O-ring: | high temperature silicone compound, composition in accordance with F.D.A. recommendations. |

The high efficiency filter media is made of certified HEPA grade borosilicate glass microfibre, having a penetration of less than 0.0001% at 0.3 μ ., equivalent to an overall efficiency $\geq 0.3 \mu$ when tested with a DOP aerosol and measured with a nucleus condensate particle counter.

Sealant remains flexible when warming-up, in order to compensate for metal parts expansion during sterilisation.

N.B.: It is User's responsibility to ensure that a suitable process for inhibiting growth of trapped bacteria and virus is respected. It is therefore recommended to sterilise the filter prior commencement of each sequence of aseptic duty. These elements are capable of withstanding sterilisation phases of 20 ÷ 30 minutes in autoclave at 120 °C (50 steps maximum executable). For "in situ" steam sterilisation, conventional steam condition for this purpose should be balanced across filter element with a small flow orifice directed from outside to in. After steam sterilisation, the element should be allowed to flash dry before the process gas is turned on. For maximum service life, it is recommended to check from time to time filter integrity. In case testing equipment is not available, it is suggested to replace the filter element every six calendar months.

FILTER ELEMENT SPECIFICATION:

| | |
|--------------------------------------|---|
| Filter grade | 0.01 μ |
| Max. temperature | 200 °C |
| Max. sterilising temperature | 138 °C (as per BS3970, part 3, cycle A) |
| Initial pressure drop, clean and dry | 150 mbar |
| Change filter element | 400 mbar |

IMPORTANT NOTE:

- *Before replacing the filter element, make sure that the o-ring and the housing are clean and lubricated with silicon compatible oil approved by F.D.A. (Food and Drug Administration)*
- *Once differential pressure limits or working hours are reached, filter element must be replaced.*
- *Only competent Personnel is allowed to install, perform maintenance or replace filter elements.*
- *It's forbidden to move or to replace any filter element from the filter housing under pressure.*



MAINTENANCE SCHEDULE CLINIC 3.40

| Year | Details | | Replacements | | | Hours |
|------|---------|-----------|--------------|---|-------|-------|
| 1 | | | / | / | / | 500 |
| 2 | Date | Signature | F2 | / | / | 1000 |
| 3 | | | / | / | / | 1500 |
| 4 | Date | Signature | F2 | / | G1 | 2000 |
| 5 | | | / | / | / | 2500 |
| 6 | Date | Signature | F2 | / | / | 3000 |
| 7 | | | / | / | / | 3500 |
| 8 | Date | Signature | F2 | / | G1+G2 | 4000 |
| 9 | | | / | / | / | 4500 |
| 10 | Date | Signature | F2 | / | / | 5000 |

| Description | Q.ty/Code |
|------------------------------------|-----------|
| F2 Air intake filters spare | 2x279 |
| G1 Seal gasket kit | 1x84303 |
| G2 Piston Kit | 1x83214 |



MAINTENANCE SCHEDULE CLINIC DRY 3.40 H / CLINIC DRY 3.40 HS

| Year | Details | | Replacements | | | Hours |
|------|---------|-----------|--------------|----|-------|-------|
| 1 | | | / | / | / | 500 |
| 2 | Date | Signature | F2 | F3 | / | 1000 |
| 3 | | | / | / | / | 1500 |
| 4 | Date | Signature | F2 | F3 | G1 | 2000 |
| 5 | | | / | / | / | 2500 |
| 6 | Date | Signature | F2 | F3 | / | 3000 |
| 7 | | | / | / | / | 3500 |
| 8 | Date | Signature | F2 | F3 | G1+G2 | 4000 |
| 9 | | | / | / | / | 4500 |
| 10 | Date | Signature | F2 | F3 | / | 5000 |

| Description | Q.ty/Code |
|------------------------------------|-----------|
| F2 Air intake filters spare | 2×279 |
| F3 Coalescent filter spare | 1×84211 |
| G1 Seal gasket kit | 1×84303 |
| G2 Piston Kit | 1×83214 |



SINGLE TABLE FOR PACKAGING DISPOSAL D.Lgs. 116/2020 (ITA) - UE 2018/852

| <i>D.Lgs. 116/2020 (ITA) - UE 2018/852</i> | | | | | | | | | |
|--|---------------|----------------------------|-------------------------------|---------------|--------------------------|--------------------------|-----------------------------|---------------------|------------------------------|
| | | | | | | | | | |
| IT | Pallet | Scatola (cartone ondulato) | Scatola (cartone pressato) | Foglio | Reggia | Reggia | Busta / Film estensibile | Protezione | Vite / Staffa / Graffa |
| | LEGNO | CARTA | CARTA | CARTA | PLASTICA | PLASTICA | PLASTICA | POLISTIROLO | FERRO |
| EN | Pallet | Box (Corrugated Cardboard) | Box (Pressed Cardboard) | Sheet | Strap | Strap | Bag / Stretch Film | Protection | Screw / Bracket / Staple |
| | WOOD | PAPER | PAPER | PAPER | PLASTIC | PLASTIC | PLASTIC | POLYSTYRENE | IRON |
| DE | Palette | Karton (Wellpappe) | Karton (Presspappe) | Papier | Band | Band | Beutel/Stretchfolie | Schutz | Schraube/Halterung/Klemme |
| | HOLZ | PAPIER | PAPIER | PAPIER | KUNSTSTOFF | KUNSTSTOFF | KUNSTSTOFF | STYROPOR | EISEN |
| FR | Palette | Boîte (carton ondulé) | Boîte (carton comprimé) | Feuille | Feuillard | Feuillard | Enveloppe/Film étirable | Protection | Vis/Attache/Agrafe |
| | BOIS | PAPIER | PAPIER | PAPIER | PLASTIQUE | PLASTIQUE | PLASTIQUE | POLYSTYRÈNE | FER |
| ES | Palé | Caja (cartón ondulado) | Caja (cartón prensado) | Hoja | Fleje | Fleje | Sobre / Película extensible | Protección | Tornillo / Estribo / Grapa |
| | MADERA | PAPEL | PAPEL | PAPEL | PLÁSTICO | PLÁSTICO | PLÁSTICO | POLIESTIRENO | HIERRO |
| FI | Kuormalava | Laatikko (aaltopahvia) | Laatikko (puristettua pahvia) | Arkki | Vanne | Vanne | Pussi / venytyskalvo | Suojus | Ruuvi / kannatin / kiinnitin |
| | PUU | PAPERI | PAPERI | PAPERI | MUOVI | MUOVI | MUOVI | POLYSTYREENI | RAUTA |
| PL | Paleta | Pudełko (tektura falista) | Pudełko (tektura prasowana) | Arkusz | Opaska | Opaska | Torebka/folia stretch | Zabezpieczenie | Śruba/uchwyt/s pinacz |
| | DREWNO | PAPIER | PAPIER | PAPIER | TWORZYWO SZTUCZNE | TWORZYWO SZTUCZNE | TWORZYWO SZTUCZNE | POLISTYREN | METAL |
| SV | Lastpall | Låda (wellpapp) | Låda (kartong) | Blad | Tyglina | Tyglina | Kuvert / sträckfilm | Skydd | Skruv / klämma / klammer |
| | TRÄ | PAPPER | PAPPER | PAPPER | PLAST | PLAST | PLAST | POLYSTIREN | JÄRN |



Via delle Tezze, 20/22
36070 TRISSINO (VI)
Italy

phone +39 0445 96 20 00
info@gentilinair.com

www.gentilinair.com