



Instruction Manual  
Compressors

**CK330/150**

**CSK330/150**

**EK660/200**

**ESK660/200**

**CE EAC**

**EN**





## INDEX

<b>1 PARTS LIST .....</b>	<b>4</b>
<b>2 TECHNICAL SPECIFICATIONS .....</b>	<b>6</b>
<b>3 CE DECLARATION OF CONFORMITY .....</b>	<b>7</b>
<b>4 CE LABEL .....</b>	<b>8</b>
<b>5 IMPORTANCE OF THE MANUAL .....</b>	<b>9</b>
<b>6 RECIPIENTS .....</b>	<b>10</b>
<b>7 STATUS "APPLIANCE OFF" .....</b>	<b>11</b>
<b>8 WARRANTY .....</b>	<b>12</b>
<b>9 RIGHTS RESERVED.....</b>	<b>13</b>
<b>10 INTENDED USE .....</b>	<b>13</b>
<b>11 INCORRECT USE .....</b>	<b>14</b>
<b>12 TRANSPORTATION AND MOVEMENT OF THE APPLIANCE .....</b>	<b>15</b>
<b>13 PACKAGING .....</b>	<b>15</b>
<b>14 UNPACKING .....</b>	<b>15</b>
<b>15 LOCATION .....</b>	<b>16</b>
<b>16 STORAGE .....</b>	<b>16</b>
<b>17 ELECTRICAL CONNECTION.....</b>	<b>16</b>
<b>18 AIR PIPE (EXTENSION) AND UTENSILS CONNECTION .....</b>	<b>17</b>
<b>19 SAFETY DEVICES ADOPTED .....</b>	<b>18</b>
<b>20 SAFETY SIGNS .....</b>	<b>20</b>
<b>21 PERSONAL PROTECTIVE EQUIPMENT (PPI) .....</b>	<b>21</b>
<b>22 RESIDUAL RISKS .....</b>	<b>21</b>
<b>23 AREAS ASSUMED BY AUTHORISED OPERATORS.....</b>	<b>22</b>
<b>24 COMMAND DEVICES .....</b>	<b>23</b>
<b>25 PRE-START-UP CHECKS.....</b>	<b>24</b>
<b>26 APPLIANCE ACTIVATION .....</b>	<b>25</b>
<b>27 APPLIANCE DEACTIVATION .....</b>	<b>26</b>
<b>28 VOLTAGE OVERLOAD SAFETY RESET .....</b>	<b>28</b>
<b>29 EMERGENCY STOP.....</b>	<b>28</b>
<b>30 START-UP SUBSEQUENT TO AN EMERGENCY STOP.....</b>	<b>29</b>
<b>31 STANDARD MAINTENANCE .....</b>	<b>29</b>
<b>32 EXTRAORDINARY MAINTENANCE.....</b>	<b>31</b>
<b>33 END OF SERVICE LIFE .....</b>	<b>31</b>
<b>34 REPLACEMENT PARTS.....</b>	<b>31</b>
<b>35 ANOMALIES - CAUSES - SOLUTIONS .....</b>	<b>31</b>



## 1. PARTS LIST

- 1) Switch
- 2) Pressure switch
- 3) Tank cap (**do not touch**)
- 4) Condensate pump
- 5) Support feet
- 6) Air outlet spigot (regulator)
- 6a) Air outlet spigot (tank)
- 7) Outlet pressure regulator
- 8) Tank outlet gauge
- 9) Non-return valve
- 10) Safety valve
- 11) Fan cover
- 12) Electric motor
- 13) Power plug and cable
- 14) Twin cylinder pump system
- 15) Tank pressure gauge
- 16) Air tank
- 17) Pump/Tank connection pipes
- 18) Air filter

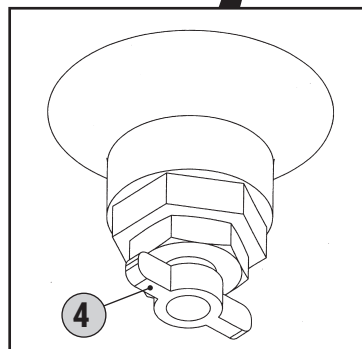
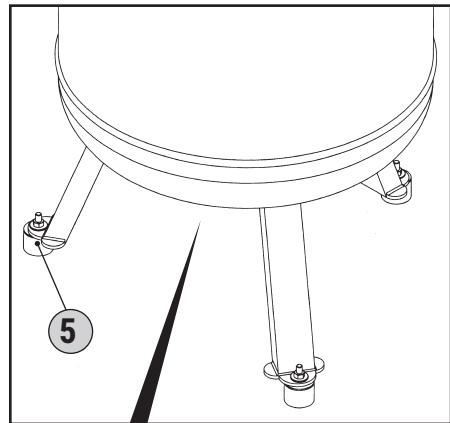
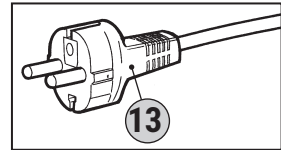

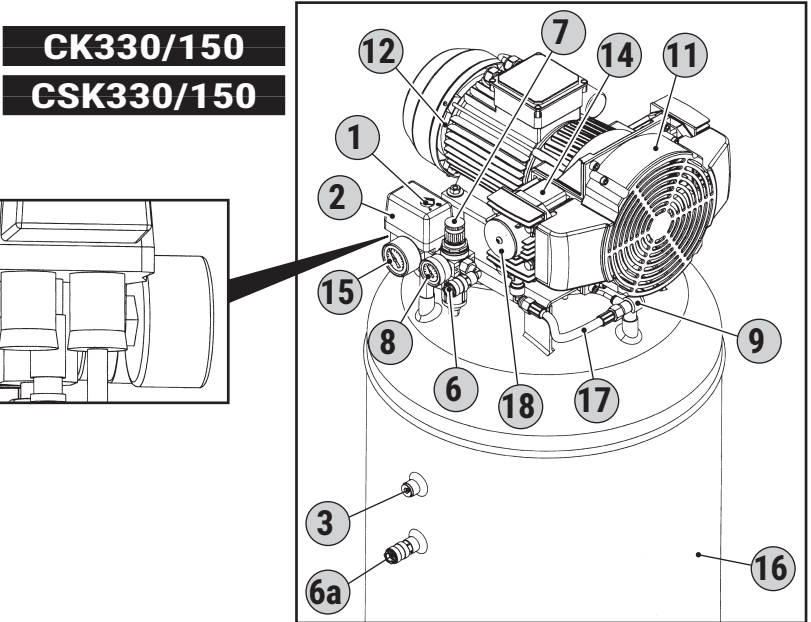
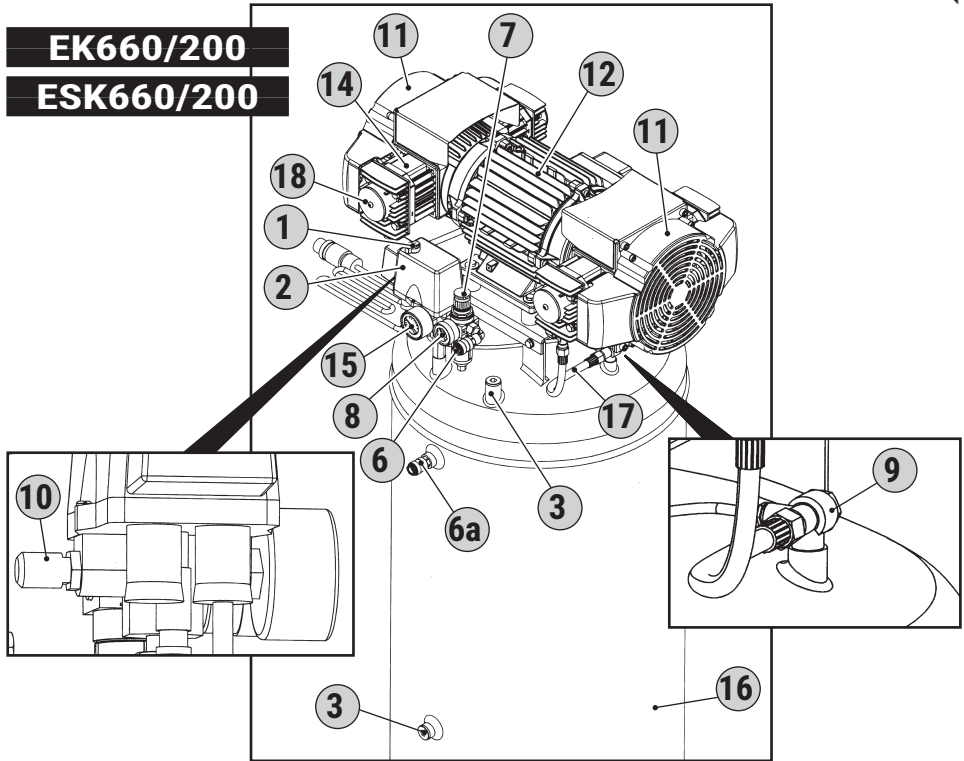



## 2. TECHNICAL SPECIFICATIONS

MODEL	CK330/150	CSK330/150	EK660/200	ESK660/200
Supply voltage/Frequency	230/50	230/50	400/50	400/50
Nominal power (kW)	2,20	1,75	4,00	3,20
Max. operating pressure (bar)	10			
Level of output noise levels A at the work stations (Leg. 2006/42/CE) (dB)	85	79	90	81
Driveshaft rotation speed (rpm)	1400			
Tank volume (l)	150	150	200	200
Performance (aspirations/yield) (l/min)	330/200	330/185	660/395	660/360
Temperature/air humidity (°C)	+5°C ÷ +40°C / 5% ÷ 95%			
Total weight (Kg)	70	71	104	106
Dimensions (A×B×C) (mm)	610×610×1428	610×610×1428	705×705×1725	705×705×1725
Motor rotation direction	The compressor can be used in both directions of rotation			

**EK660/200**

**ESK660/200**

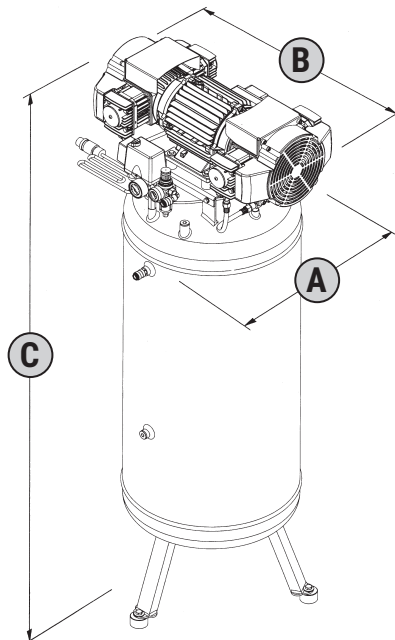

**CK330/150**

**CSK330/150**

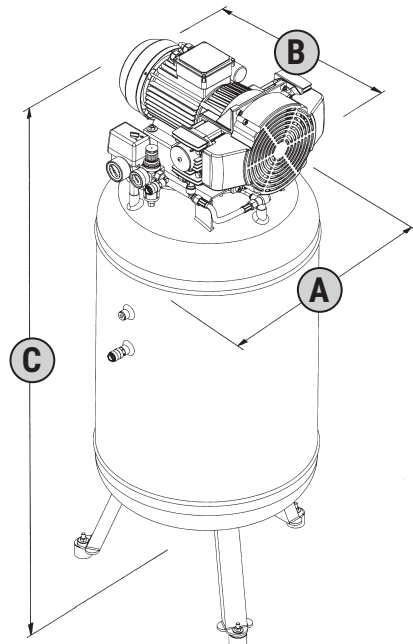



### 3. CE DECLARATION OF CONFORMITY

**Gentilin S.r.l.** - Via delle Tezze, 20/22 36070 Trissino (VI) - Italy  
VAT N.: **01262520248**

Declares that the following machine:

**COMPRESSOR CK330/150 - CSK330/150 - EK660/200 - ESK660/200**

MACHINE: **Air volumetric compressor**

SERIAL NUMBER: \_\_\_\_\_

Complies with the following directives:

- **2006/42/EC** Directive of the European Parliament and the Council of 17 May 2006 on machinery and amending Directive 95/16/EC (recast)
- **2014/30/UE** Directive of the European Parliament and of the Council of 26 February 2014, replacing 2004/108/EC Directive of the European Parliament and of the Council of 15 December 2004, on the approximation of the laws of the Member States relating to electromagnetic compatibility and repealing Directive 89/336/EEC
- **2014/35/UE** Directive of the European Parliament and of the Council of 26 February 2014, replacing Directive 2006/95/EC of the European Parliament and Council, of December 12, 2006

Person authorized to prepare the Technical Dossier **Gentilin Giuseppe**, in quality of Technical Manager

Place: **Via delle Tezze, 20/22 - 36070 Trissino (VI) ITALY**

Date: \_\_\_\_\_

Legal Representative  
**(Gentilin Giampaolo)**  
Signature:





## 4. CE LABEL

The CE label serves as evidence of the appliance's compliance with essential health and safety requirements as specified by the **Machinery Directive 2006/42/CE**. It takes the form of a polyester sticker, with a black thermal transfer mould, which are applied on the motor frame.

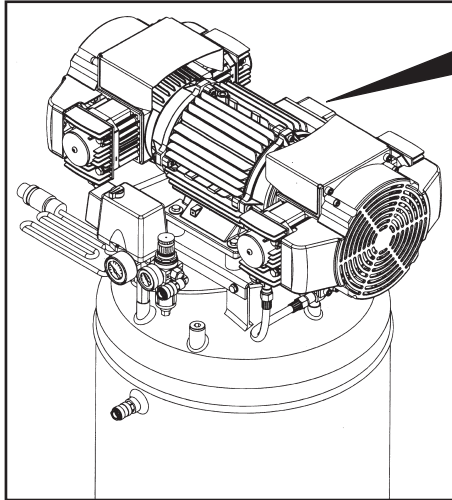

**EK660/200**  
**ESK660/200**

MODELLO MODEL		NUMERO DI SERIE SERIAL NUMBER
XXX/XX		XXXXXX0001/YY
POTENZA NOMIN. Rated power	VELOCITÀ NOMIN. -1 Shaft speed	PROTEZ. TERMICA Term. Prot.
2.2Kw	1400rpm	S06-160°C
CLASSE DI SERVIZIO Service class	FATTORE DI POTENZA COS φ	GRADO DI PROTEZ. IP
S1	0.90	IP44
TENSIONE Tensione	FREQUENZA Frequency	CORRENTE NOMIN. Rated current
230V	50Hz	9.6A
IEC/EN	TEMP. MAX AMBIENTE Max ambient temp.	CLASSE DI ISOLAMENTO Insulation class
60034	40°C	F
ANNO DI COSTRUZIONE Built year	PRESS. MAX ESERCIZIO Max work pres.	PESO COMPRES. Weight
2020	10 BAR	32Kg
GENTILIN S.R.L. - Via delle Tezze 20/22 - 36070 Trissino (VI) Italy - VAT/P.Iva 01262520248		

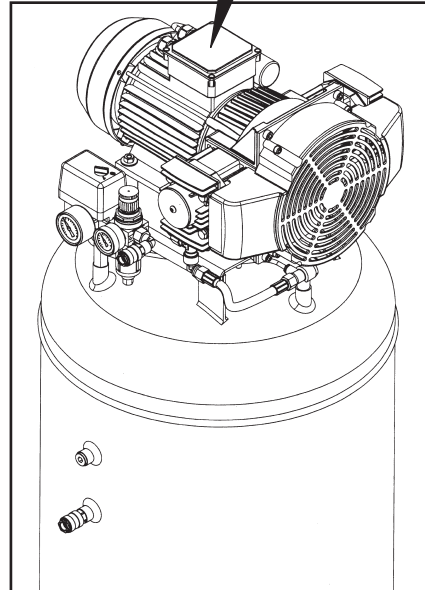

**CK330/150**  
**CSK330/150**



## 5. IMPORTANCE OF THE MANUAL



**BEFORE USING THE APPLIANCE IN QUESTION, AUTHORISED USERS MUST READ AND UNDERSTAND THE PRESENT INSTRUCTION MANUAL IN ITS ENTIRETY.**

- The “Instruction Manual” was compiled according to the instructions as specified in **Machinery Directive 2006/42/CE**, in order to guarantee easy and correct understanding of subjects relevant to operators authorised to use and oversee maintenance of the appliance in question. Should operators find errors, please do not send incorrect personal interpretations/amendments that may threaten safety, rather, we advise you immediately request the Manufacturer send the correct explanations or further details.
- The “Instruction Manual” must be accessible by authorised operators at all times and must be always be kept in a safe place within close proximity of the appliance.



**THE PRESENT INSTRUCTION MANUAL FORMS AN INTEGRAL PART OF THE APPLIANCE AND MUST BE KEPT FOR FUTURE REFERENCE AND UP UNTIL THE END OF APPLIANCE LIFE. IT MUST ALWAYS BE ACCESSIBLE TO AUTHORISED OPERATORS AND IT MUST BE SAFELY STORED AND KEPT WITHIN CLOSE PROXIMITY OF THE APPLIANCE ITSELF.**

**THE MANUFACTURER DECLINES ANY RESPONSIBILITY FOR DAMAGE TO PERSONS, ANIMALS AND OBJECTS CAUSED BY INOBSERVATION OF REGULATIONS AND WARNINGS DESCRIBED IN THE PRESENT INSTRUCTION MANUAL.**

**IN THE INSTANCE WHERE THE INSTRUCTION MANUAL IS LOST OR DAMAGED, RERQUEST A COPY FROM THE MANUFACTURER OR THE AUTHORISED SUPPLIER, SPECIFYING THE APPLIANCE MODEL AND THE EDITION NUMBER PROVIDED WITHIN THE TITLE.**

**THE PRESENT INSTRUCTION MANUAL COMPLIES WITH TECHNICAL PROVISIONS AT THE TIME OF PURCHASE OF THE APPLIANCE AND CANNOT BE CONSIDERED INCORRECT IN THE INSTANCE WHERENEWEXPERIMENTATION RESULTS IN UPDATES OF SUCH TECHNICAL PROVISIO.**

**THE PRESENT INSTRUCTION MANUAL MUST BE PASSED OVER IN THE INSTANCE WHERE THE APPLINACE IS HANDED OVER TO ANOTHER USER.**



## 6. RECIPIENTS

This "Instruction Manual" is aimed exclusively at operators authorised to carry out operations according to specific technical skills necessitated for the operation type.



**AUTHORISED OPERATORS MUST ONLY CARRY OUT OPERATIONS FOR WHICH THEY ARE QUALIFIED.**

**BEFORE CARRYING OUT ANY OPERATIONS, AUTHORISED OPERATORS MUST POSSESS ADEQUATE PSYCHO-PHYSICAL CAPABILITIES IN ORDER TO ALWAYS ENSURE SAFETY.**

### ASSIGNED OPERATOR



An operator over the age of 18 (private user or employee) and, who, in compliance with current legislation on health and safety in the work place in force within the country of usage, is capable of exclusively activating, using and deactivating the appliance whilst completely complying with the instructions presently provided, **whilst using the dedicated personal safety device items.**

### MECCANICAL/PNEUMATIC MAINTENANCE PERSON



A qualified technician, capable of carrying out exclusive interventions on mechanical/pneumatic parts in order to oversee the regulation, maintenance and/or repairs even with protective devices disabled in complete compliance with the instructions presently provided or with any other specific document supplied by the Manufacturer, **whilst using the dedicated personal safety device items.**

### ELECTRICAL MAINTENANCE



A qualified technician, capable of carrying out exclusive interventions on electrical devices in order to oversee the regulation, maintenance and/or repairs even where an electric supply is present and even with protective devices disabled in complete compliance with the instructions presently provided or with any other specific document supplied by the Manufacturer, **whilst using the dedicated personal safety device items.**

### COMPANY SAFETY MANAGER



A qualified technician nominated by the employer (where the appliance is used in a business context), who possesses the required professional, technical skills as specified by the legislations currently in force on health and safety of workers at the work place.



## MANUFACTURER'S TECHNICIAN



A qualified technician offered by the Manufacturer and/or Supplier authorised to provide required technical assistance, standard and extraordinary maintenance interventions and/or operations which are not presently included which necessitate specialist knowledge of the appliance, **whilst using the dedicated personal safety device items.**

## 7. STATUS "APPLIANCE OFF"

**Before carrying out any type of maintenance and/or regulation operation on the appliance, you must:**

- Shut off the power supply ensuring that the switch (1) is in the "OFF (0)" position.
- Unplug the power cable from the plug located near the appliance.
- Empty the tank (16) (no pressure).

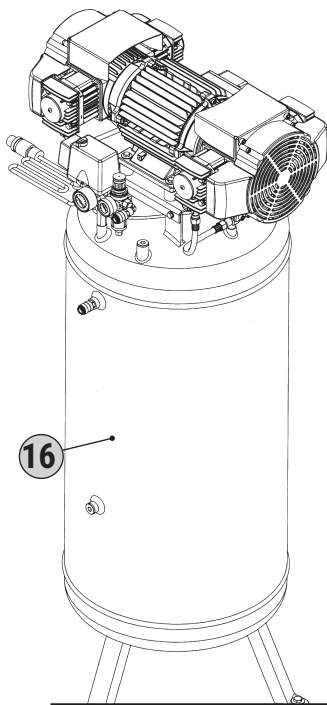

**EK660/200**  
**ESK660/200**

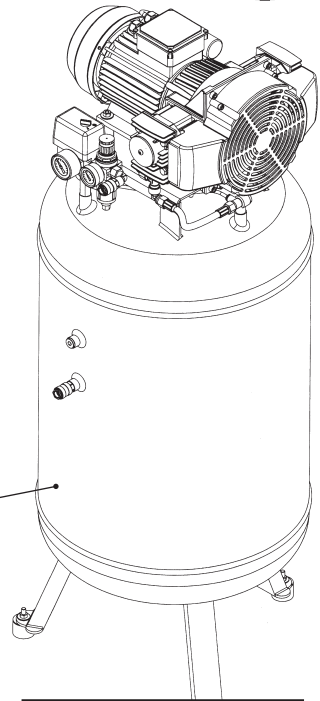
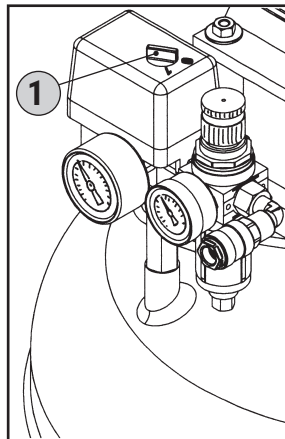

**CK330/150**  
**CSK330/150**



## 8. GUARANTEE

- 1) **GUARANTEE DECLARATION:** the Manufacturer gives an undertaking to the End-User to replace, repair or otherwise intervene in the machine, if it has conformity defects that compromise its correct use and operation, but only if such defects are attributable to the actual liability of the Manufacturer. The Manufacturer reserves the right to adopt the optimal solution to restore the conformity of the machine within a reasonable period of time. The guarantee does not cover parts of the Products subject to normal wear and tear and/or deterioration or defects resulting from inappropriate transport.
- 2) **END-USER:** the End-User is the person who buys the machine to use it directly. The End-User who buys the machine as a natural person for purposes that do not fall within the scope of commercial or professional activity is defined as a “consumer”. The End-User is defined as a “professional or company” when the purchase is made by a professional or by a company acting for purposes which fall within the scope of its commercial or professional activity.
- 3) **TERMINALS:** the Manufacturer is liable to the End-User when the lack of conformity occurs within the following terms from the date of purchase:  
**24 months** if the purchase was made by a ‘consumer’ as described in point 2).  
**12 months** if the purchase was made by a “professional or company” as described in point 2).  
All End-Users have the right to extend the guarantee (Extended Guarantee) for up to three years from the date of purchase of the machine if they: (a) have registered their purchase on the website [www.gentilinair.com](http://www.gentilinair.com) within seven days of purchase and (b) have completed the registration form completely and accurately, filling in the required fields with exact, complete and true information and have kept the registration code to be mentioned in the event of problems. Replaced parts or products will remain under guarantee until the original product guarantee expires.
- 4) **VALIDITY:** the guarantee is valid if the End-User notifies the Manufacturer of the conformity defect within 2 months from the date on which he has discovered it, but within the final term indicated in point 3) above. The above report must be accompanied by a regular purchase document (tax receipt or invoice). In the case of an Extended Guarantee, the declaration must also indicate the registration code.
- 5) **FORFEIT:** the guarantee will be void if the purchaser uses the machine improperly and/or not in accordance with the provisions of this “Instruction Manual” provided by the Manufacturer, or if the lack of conformity was caused by inexperience on the part of the purchaser or by chance. The use of the products after the discovery of defects releases the Manufacturer from any guarantee commitment or liability.
- 6) **LIABILITY:** the Manufacturer is released from any liability resulting from any damage sustained by the purchaser, resulting from loss or diminution of production which derives from any lack of conformity.
- 7) **COSTS:** the End-User has the right to the restoration of the conformity of the machine under guarantee without any costs for labour or materials. The shipping methods must be agreed with the authorised dealer or with the Manufacturer. In the event that the non-conformity is only apparent or the complaint arrives after the deadline, the Manufacturer may charge the cost of both transport and any repair that is indicated by the authorised dealer or the Manufacturer.



## 9. RIGHTS RESERVED

- Rights reserved with regards the “Instruction Manual” remain with the Manufacturer.
- No parts of the present manual, in full or in part, may be copied and/or passed on in any way, without written authorisation from the Manufacturer.
- All the brands mentioned belong to the respective owners.

## 10. INTENDED USE

### FIELD OF OPERATION

Industrial, handicraft and civil.

### PLACE OF OPERATION

Interior locations with sufficient lighting, ventilation, with temperature and air humidity values as per details provided in Paragraph 2, in compliance with legislation governing health and safety in the work place in force in the country of usage. The appliance must rest on a surface that ensures the appliance is stable with respect to its weight and overall dimensions (see Paragraph 2).



#### **WARNING!**

**THE APPLIANCE MUST BE KEPT OUT OF REACH OF CHILDREN.**

### INTENDED USE

Compressing air (no oil) to be used with suitable pneumatic utensils according to current legislation in force (E.g. blowing, pumping, washing, veneering and sandblasting, etc.).

### OPERATORS AUTHORISED USE

An authorised operator with professional, technical skills as described in Paragraph 6.



## 11. INCORRECT USE

The appliance was designed and manufactured exclusively for the aim as described in Paragraph 10; in order to ensure the safety of authorised operators and appliance efficiency at all times, any other use is completely forbidden.



**IT IS COMPLETELY FORBIDDEN TO OPERATE THE APPLIANCE IN ENVIRONMENTS PRONE TO EXPLOSIONS AND/OR WHERE COMBUSTIBLE SUBSTANCES ARE PRESENT (E.G. WOOD GRAINS, FLOUR, SUGAR AND GRANULES).**

**IT IS ABSOLUTELY FORBIDDEN TO USE THE MACHINE IN AREAS CONTAINING SOLID OR ABRASIVE PARTICLES.**

**DANGER OF BURNS UPON ACCIDENTAL CONTACT WITH TWIN CYLINDER PUMP SYSTEM AND ELECTRICAL MOTOR. WARNING – RESIDUAL RISK (SEE PARAGRAPH 22).**

**THE MACHINE MUST BE USED IN COMPLIANCE WITH LEGISLATION GOVERNING EMISSIONS (NOISE) IN FORCE IN THE COUNTRY OF USE.**

**DURING USE, ENSURE THAT UNAUTHORISED PERSONS DO NOT COME WITHIN PROXIMITY OF THE APPLIANCE.**

**THE APPLIANCE MUST BE KEPT OUT OF THE REACH OF CHILDREN.**

**IT IS STRICTLY FORBIDDEN TO USE THE MACHINE OUTDOORS.**

**INCORRECT USE OF THE APPLIANCE OR USE WHICH DIFFERS FROM THAT SPECIFIED IN PARAGRAPH 10 IS FORBIDDEN.**

**THE USE OF UNSUITABLE AIR PIPES (EXTENSIONS), CONNECTIONS AND UTENSILS OR THOSE WHICH DO NOT CONFORM WITH CURRENT LEGISLATION IN FORCE ARE COMPLETELY FORBIDDEN.**

**IT IS FORBIDDEN TO LIFT THE APPLIANCE WITH CRANES AND/OR LIFTING DEVICES.**

**IT IS FORBIDDEN TO DIRECT COMPRESSED AIR JETS AT PERSONS AND/OR ANIMALS.**

**IT IS FORBIDDEN TO USE THE APPLIANCE TO MOVE AND/OR LIFT PERSONS, ANIMALS OR OBJECTS.**

**IT IS FORBIDDEN TO MOUNT THE APPLIANCE.**

**IT IS FORBIDDEN TO TOW THE APPLIANCE USING ANY TYPE OF MEDIUM AND/OR VEHICLE.**

**IT IS FORBIDDEN TO MANUALLY MOVE THE APPLIANCE UPHILL AND/OR DOWNHILL WHERE DANGEROUS INCLINATIONS ARE PRESENT.**



## 12. TRANSPORTATION AND MOVEMENT OF THE APPLIANCE

The machine can be transported by transpallet or forklift.

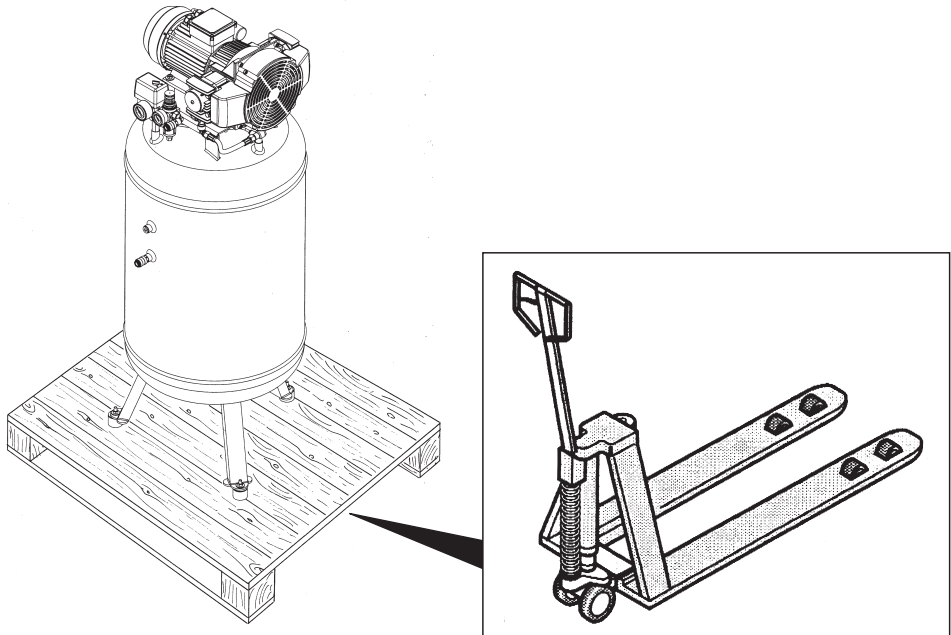

## 13. PACKAGING

The machine is packed by the Manufacturer on a pallet, fixed with straps and covered with shrink film and can only be moved using a fork lift truck or a transpallet. The pack contains 1 compressor and 1 instructions manual.

## 14. UNPACKING

Once the package has been placed on the floor on a flat surface which ensures stability, proceed with unpacking; remove the appliance from its packaging as per the instructions provided in Paragraph 12.



**PLEASE DISPOSE OF THE PACKAGING DIVIDING IT UP ACCORDING TO THE VARIOUS WASTE MATERIALS AND IN COMPLIANCE WITH LEGISLATION CURRENTLY IN FORCE IN THE COUNTRY OF USAGE.**



## 15. LOCATION

The appliance must be placed in a work place which satisfies the characteristics described in Paragraph 10; it must be placed on a flat surface which ensures stability with regards to overall dimensions and weight (see Paragraph 2).



**IN ORDER TO ENSURE A SAFE WORKING ENVIRONMENT FOR AUTHORISED OPERATORS, WE RECOMMEND PLACING THE APPLIANCE AT A MINIMUM DISTANCE OF 1m FROM OTHER OBJECTS/ENTITIES.**

## 16. STORAGE

- In the instance where the appliance is not to be used for an extended period of time, it must be stored in a safe place, with suitable temperature and air humidity values, where it is protected from dust.
- Before storing the appliance, we recommend draining moisture from the air tank.

## 17. ELECTRICAL CONNECTION

The machine can be connected to the mains electrical supply by plugging the power cable into the special socket (13).

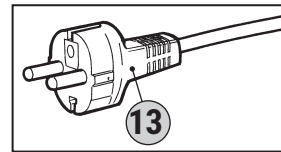

**THE POWER SUPPLY NETWORK TO WHICH THE APPLIANCE IS CONNECTED MUST CONFORM TO THE LEGISLATION CURRENTLY IN FORCE IN THE COUNTRY OF USAGE, CONFORM TO THE TECHNICAL SPECIFICATIONS PROVIDED IN PARAGRAPH 2 AND BE EQUIPPED WITH A SUITABLE "PLANT EARTHING" SYSTEM.**

**ALL MATERIALS USED FOR ELECTRICAL CONNECTION MUST BE SUITED TO THE INTENDED USAGE, LABELLED WITH "CE" IF SUBJECT TO THE LOW VOLTAGE DIRECTIVE 2006/95/CE AND CONFORM TO THE REQUIREMENTS AS SPECIFIED IN THE LEGISLATION CURRENTLY IN FORCE IN THE COUNTRY OF APPLIANCE USAGE. DISREGARD FOR THE ABOVE DESCRIBED WARNINGS MAY LEAD TO IRREPERABLE DAMAGE TO THE APPLIANCE ELECTRICAL SYSTEM AND SUBSEQUENTLY WARRANTY EXPIRY.**

**THE MANUFACTURER DECLINES ANY RESPONSIBILITY FOR FAULTS OR ANOMOLIES WITH APPLIANCE OPERATION CAUSED BY ELECTRICAL POWER SURGES IN ADDITION TO TOLERANCES BY THE SUPPLY ENTITY (VOLTAGE  $\pm$  10%, FREQUENCY  $\pm$  2%).**



**WHERE NECESSARY, CONNECT THE APPLIANCE EXCLUSIVELY TO THE ELECTRICAL SUPPLY GENERATOR WITH POWER GRTEATER THAN THE INSTALLED ELECTRICAL POWER (SEE PARAGRAPH 2), IN ORDER TO SUPPORT THE POWER-DRAWAT START-UP.**

## 18. AIR PIPE (EXTENSION) AND UTENSILS CONNECTION

- Connect the utensil to the air pipe (extension).
- Connect the air pipe (extension) to the appliance air outlet (tank or regulator) spigot (rif. 6-6a).



**THE MANUFACTURER DECLINES ANY RESPONSIBILITY FOR DAMAGE TO PERSONS, ANIMALS AND OBJECTS CAUSED BY THE INOBSERVATION OF THE ABOVE DESCRIBEDWARNINGS.**

**AIR PIPES (EXTENSION), CONNECTIONS AND UTENSILS WHICH CONFORM TO THE MANUFACTURER'S INSTRUCTION MANUALS MUST BE USED.**

**THE USE OF UNSUITABLE AIR PIPES (EXTENSIONS), CONNECTIONS AND UTENSILS AND/OR THOSE WHICH DO NOT COMPLY WITH LEGILATION CURRENTLY IN FORCE IS STRICTLY FORBIDDEN.**

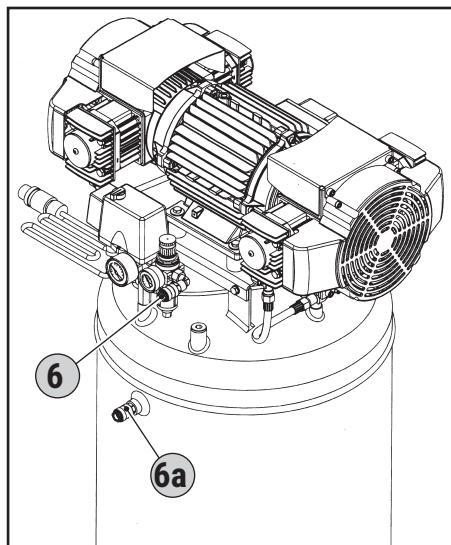

**EK660/200**  
**ESK660/200**

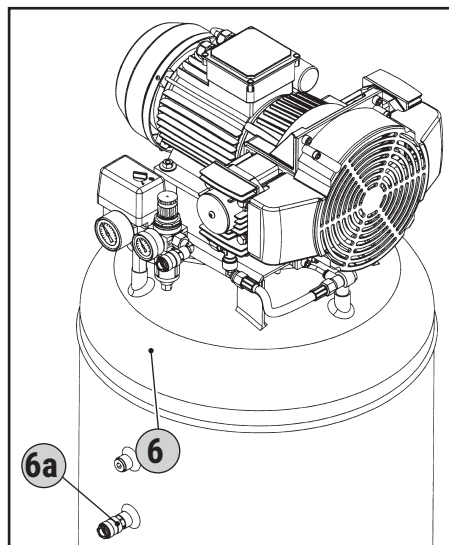

**CK330/150**  
**CSK330/150**



## 19. SAFETY DEVICES ADOPTED

**SAFETY VALVE (10):** a certified safety valve (set to 10.5 bar), installed to the pneumatic system, under the pressure switch. It tackles over-pressure in the instance where, owing to anomalies, the pressure switch does not function. Safety valve intervention ensures the operator switches off the appliance and requests the support of maintenance persons.

**PRESSURE SWITCH (2):** an electro-pneumatic device (set to a minimum of 7 bar and a maximum of 10 bar) installed to the pneumatic system. It serves to control the automatic start-up of the appliance when the operating pressure comes down to 7 bar and the automatic close-down when the pressure reaches 10 bar.

**FAN COVER (11):** fixed protection made of plastic attached using screws fixed to the twin cylinder pump system base. It serves to stop accidental contact with the cooling fan when in motion.

**TANK PRESSURE GAUGE (15):** a measuring device installed to the appliance tank. It displays the compressed air pressure inside the tank.

**OUTLET PRESSURE GAUGE (8):** a measuring device installed to the appliance pneumatic system above the air outlet spigot. It displays the outlet pressure, which can be adjusted using the relative pressure regulator (0÷10 bar) (7).



**ALL SAFETY DEVICES INSTALLED ON THE APPLIANCE MUST BE REGULARLY CHECKED TO ENSURE THEY ARE FUNCTIONING CORRECTLY.**

**ANY SAFETY DEVICES WHICH ARE NOT FUNCTIONING CORRECTLY OR WHICH ARE DAMAGED MUST BE IMMEDIATELY REPLACED.**

**THE HANDLING, EXCLUSION AND/OR REMOVAL OF SAFETY DEVICES INSTALLED ON THE DEVICE IS STRICTLY FORBIDDEN.**

**REPLACING A SAFETY DEVICE OR COMPONENTS OF SAFETY DEVICES WITH UNORIGINAL REPLACEMENT PARTS IS STRICTLY FORBIDDEN.**



**EK660/200**  
**ESK660/200**

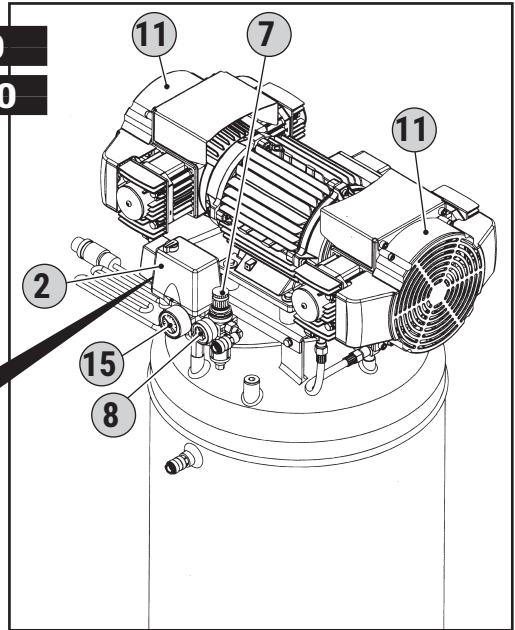
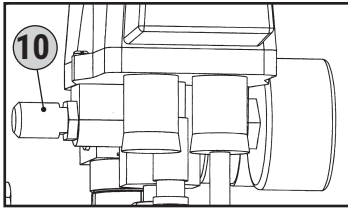

**CK330/150**  
**CSK330/150**

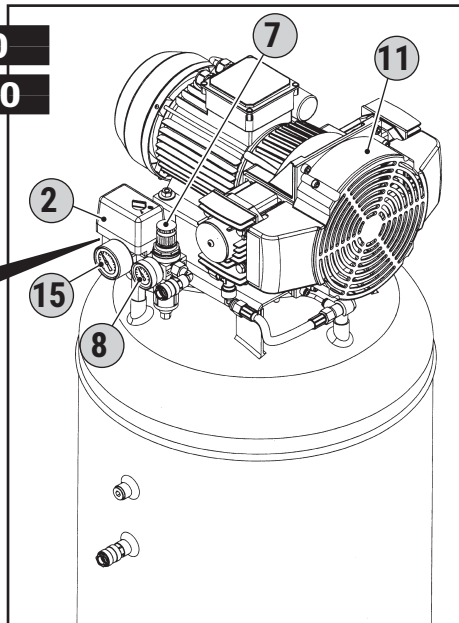
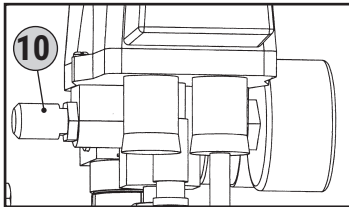



## 20. SAFETY SIGNS

Safety signs used take the form of a sticky label, applied to the appliance exterior.

### Sign definitions:

- 1) Warning – electrical power.
- 2) Warning – automatic start-up.
- 3) Warning – high temperature.
- 4) Instructions must be read.
- 5) Power must be disconnected.
- 6) Protect your hearing.



1



2



3



4



5



6



**THE SAFETY SIGN MUST BE KEPT CLEAN SO THAT IT IS VISIBLE.**

**SAFETY SIGNS WHICH ARE DAMAGED MUST BE REPLACED; ASK FOR A REPLACEMENT FROM THE MANUFACTURER OR THE AUTHORISED SUPPLIER.**

**REMOVING AND/OR DAMAGING THE SAFETY SIGN ATTACHED TO THE APPLIANCE IS STRICTLY FORBIDDEN.**





## 21. PERSONAL PROTECTIVE EQUIPMENT (PPI)



**PERSONAL PROTECTIVE EQUIPMENT ISSUED BY THE MANUFACTURER MUST BE USED.**

**AUTHORISED OPERATORS MUST WEAR PERSONAL PROTECTIVE EQUIPMENT ISSUED BY THE MANUFACTURERS OF THE UTENSILS EMPLOYED BASED UPON THE WORK TO BE CARRIED OUT.**

**AUTHORISED OPERATORS MUST NOT WEAR CLOTHING AND/OR ACCESSORIES THAT MAY BECOME CAUGHT IN THE APPLIANCE.**

SIGN	COMPULSORY PPE	TYPE OF WORK
	<b>Hand protection</b> (heat-resistant gloves)	In the instance where maintenance interventions have to be carried out whilst the electric motor and the twin cylinder pump system are still hot.
	<b>Ear protectors</b> ( earmuffs)	During all operational phases.
	<b>Feet protection</b> (shoes with reinforced toe caps)	During appliance transportation.

## 22. RESIDUAL RISKS

Although the Manufacturer has adopted all technical construction solutions in order to make the appliance as safe as possible, authorised operators please be aware that residual risks remain.

<b>RESIDUAL RISK</b>	Danger of burns upon accidental contact with the twin cylinder pump system and the electric motor.
<b>SEVERITY OF DAMAGE</b>	Mild damage (normally reversible).
<b>LIABILITY</b>	Liability may be incorporated in the instance when the operator decides to voluntarily carry out an incorrect or forbidden action.
<b>PROBABILITY</b>	Small and accidental.
<b>PHASE IN WHICH THE RISK IS PRESENT</b>	Operation.
<b>SUITABLE PROVISIONS</b>	Safety signs (see Paragraph 20). Commitment to use personal protection equipment (PPI) (see Paragraph 21) and/or waiting for the appliance to cool.



## 23. AREAS ASSUMED BY AUTHORISED OPERATORS

**AREA A:** on the rear side of the appliance next to the command devices , in order to command the activation and deactivation of the compressor, to carry out connection/disconnection of the utensils, reading of the gauge and the regulation of the pressure, cleaning or replacement of the air filter and opening/closure of the condensate pump.

**AREA B:** when working to carry out suitable operation dependent on the type of utensil used (E.g. veneering, etc.).

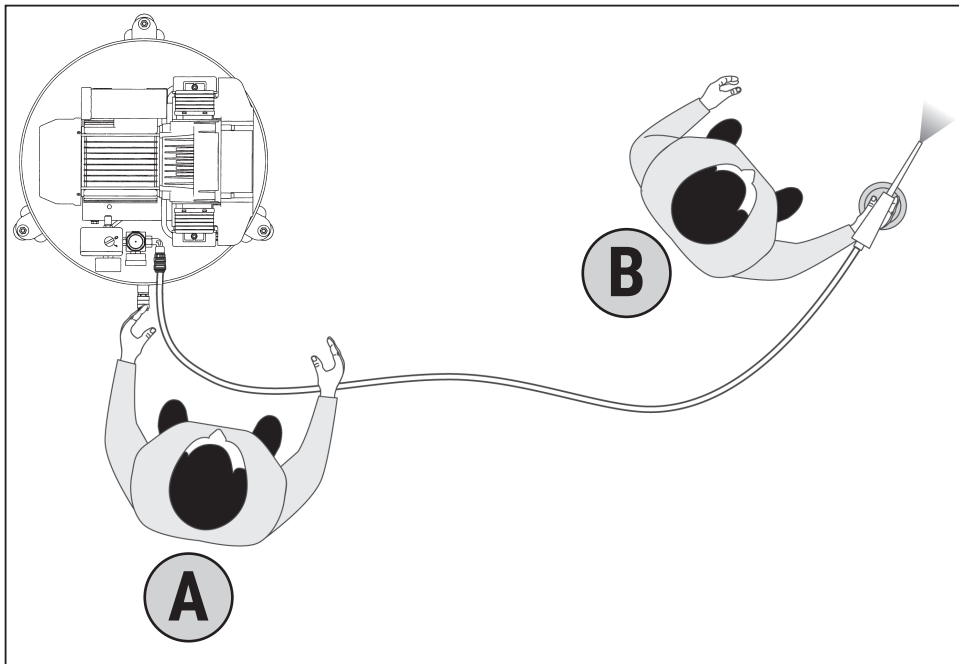



## 24. COMMAND DEVICES

The command devices are:

- 1) Electrical supply cable
- 2) Pressure switch
- 3) "ON-OFF" switch
- 4) Outlet pressure regulator
- 5) Air outlet spigot (regulator)
- 5a) Air outlet spigot (tank)
- 6) Tank pressure gauge
- 7) Tank outlet gauge
- 8) Safety valve

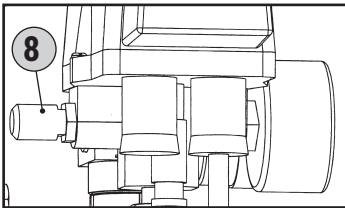
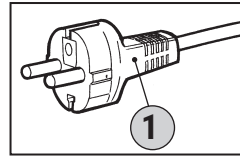

**EK660/200**  
**ESK660/200**

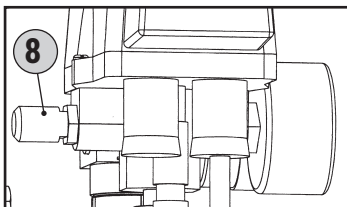
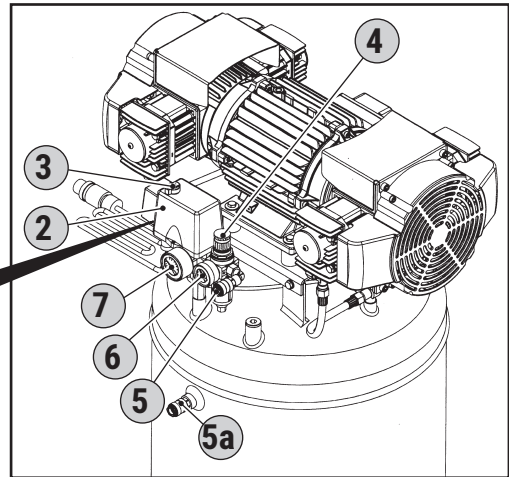

**CK330/150**  
**CSK330/150**

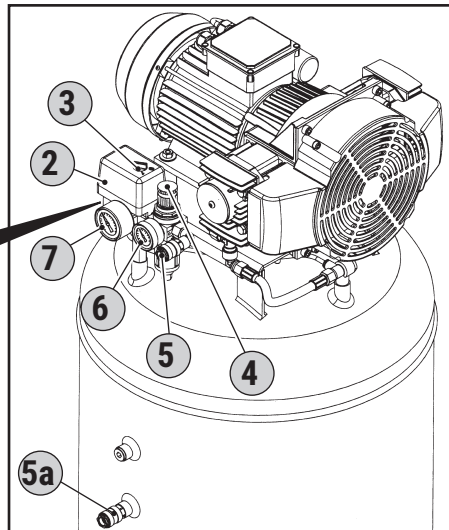



## 25. PRE-START-UP CHECKS



**BEFORE STARTING UP THE APPLIANCE, AUTHORISED OPERATORS MUST CARRY OUT THE FOLLOWING CHECKS.**

- Ensure that no unauthorised persons are in close proximity of the appliance.
- Ensure that safety devices are not damaged and that they are correctly installed and operational (see Paragraph 19).
- Ensure that the appliance is correctly positioned (see Paragraph 15).
- Ensure that the switch (1) is in the "OFF (0) position (see Paragraph 24).
- Ensure that the condensate pump is closed (A).
- Use the compulsory personal protection equipment (PPI) (see Paragraph 21).
- Ensure that you have read and understood all parts of the present "Instruction Manual".

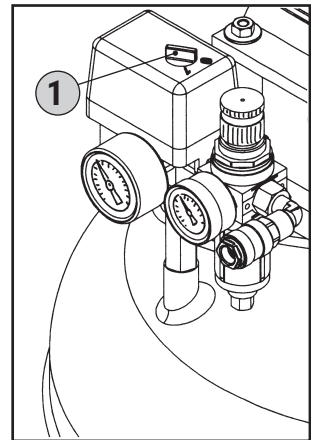
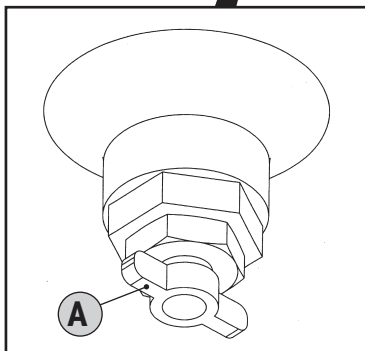
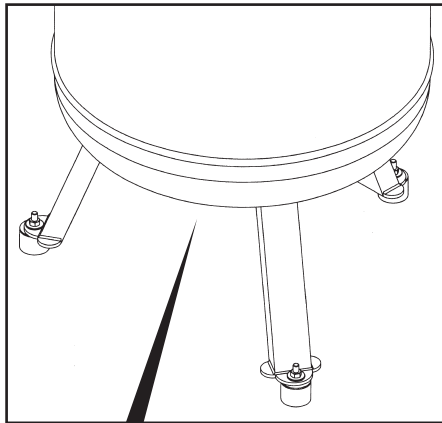



## 26. APPLIANCE ACTIVATION



**DANGER OF BURNS UPON ACCIDENTAL CONTACT WITH THE TWIN CYLINDER PUMP SYSTEM AND ELECTRIC MOTOR. WARNING – RESIDUAL RISK (SEE PARAGRAPH 22).**

**THE MANUFACTURTER DECLINES ANY RESPONSIBILITY FOR DAMAGE TO PERSONS, ANIMALS OR OBJECTS CAUSED BY INOBSERVANCE OF REGULATIONS AND THE WARNINGS DESCRIBED IN THE PRESENT MANUAL.**

**THE MANUFACTURTER DECLINES ANY RESPONSIBILITY FOR THE OUTCOME FOLLOWING USAGE AS THIS IS DEPENDENT ON THE UTENSIL USED AND THE PROFESSIONAL SKILLS OF THE AUTHORISED OPERATORS.**

**THE AUTHORISED OPERATORS MAY ONLY START UP THE APPLIANCE ONLY AFTER HAVING CARRIED OUT THE COMPLUSARY CHECKS DESCRIBED IN PARAGRAPH 25.**

**BEFORE USING THE APPLIANCE IN QUESTION, AUTHORISED OPERATORS MUST READ AND UNDERSTAND ALL PARTS OF THE PRESENT MANUAL.**

**DURING OPERATION, PLEASE ENSURE THAT UNAUTHORISED PERSONS DO NOT COME WITHIN PROXIMITY OF THE APPLIANCE.**

**AUTHORISED OPERATORS MUST NOT LEAVE THE APPLIANCE UNSUPERVISED WHILST IN OPERATION OR DURING MAINTENANCE INTERVENTIONS.**



- Connect the appliance to the power supply **(1)** by plugging it in.
- Switch on the appliance using the switch **(3)** ensuring it is in the “ON (I)” position (the appliance is operational until it reaches a maximum operating pressure of 10 bar, after which, it switches off automatically).
- Regulate the outlet pressure using the relevant regulator **(4)** according to the utensil used and type of work. Control the pressure displayed by the relevant gauge **(6)**.



**DO NOT FULLY SCREW THE OULET PRESSURE GAUGE (4) OR YOU RISK DAMAGING THE MEMEBRANE.**

- Connect the utensil to the air pipe (extension).
- Connect the air pipe (extension) to the air outlet spigot (regulator or tank) **(5-5a)**.



**AIR PIPES (EXTENSIONS), CONNECTIONS AND UTENSILS WHICH CONFORM TO DETAILS AS SPECIFIED IN THE INSTRUCTION MANUALS PROVIDED BY THE RELEVANT MANUFACTURERS MUST BE USED.**

**IT IS STRICTLY FORBIDDEN TO USE UNSUITABLE AIR HOSES (EXTENSIONS), FITTINGS AND TOOLS THAT DO NOT COMPLY WITH CURRENT REGULATIONS.**

- Carry out operations (the appliance will re-start automatically in the instance where the operating pressure falls below 7 bar).
- Upon termination of operations, switch off the appliance as described in Paragraph 27.

## 27. APPLIANCE DEACTIVATION

**At the end of operations, switch off the appliance as follows:**

- Switch off the appliance using the switch **(3)** ensuring it is set to “OFF (0)”.
- Disconnect the appliance from the power supply **(1)** by unplugging it.
- Disconnect the utensil from the air pipe (extension).
- Disconnect the air pipe (extension) from the appliance air outlet spigot (regulator or tank) **(5-5a)**.
- Drain the tank condensate pump only once the work cycle is terminated **(A)**.

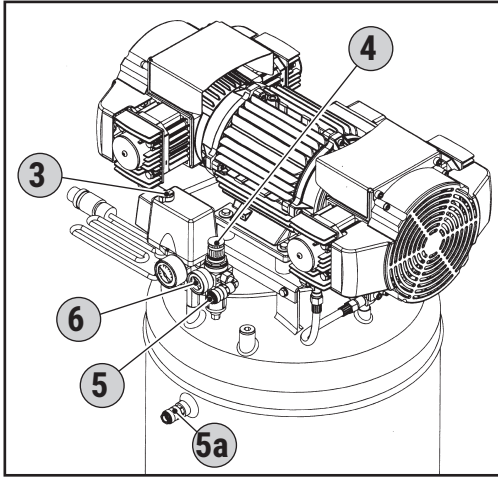

**EK660/200**  
**ESK660/200**

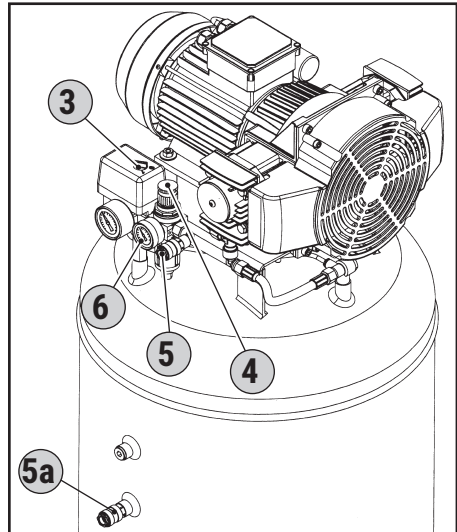
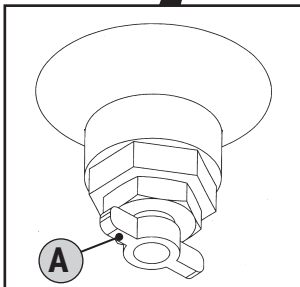
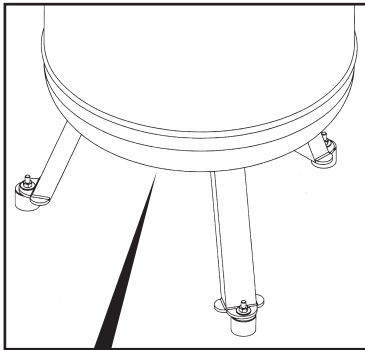
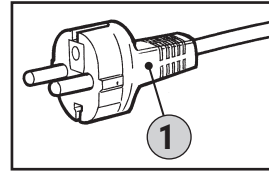

**CK330/150**  
**CSK330/150**



## 28. VOLTAGE OVERLOAD SAFETY RESET

In the instance where current overload and/or a short circuit of the appliance electrical system is noted, a safety device intervenes, disabling the electric motor.

**To carry out the reset intervention, proceed as follows:**

- Turn the switch (3) to the "OFF (0)" position.
- Press the thermal restore button (A).
- Wait a few minutes, then turn on the machine again.



**IF, AFTER CARRYING OUT THERMAL RESTORE, THE APPLIANCE DOES NOT RESTART, THE QUALIFIED OPERATOR MUST REQUEST THE INTERVENTION OF MAINTENANCE PERSONS AND/OR THE AUTHORISED SUPPLIER.**

## 29. EMERGENCY STOP

Appliance emergency stop can be carried out by turning the "ON-OFF" switch (3) to the "OFF (0)" position. In order to avoid any possible danger, authorised operators must carry out the following operations.

- **IMMEDIATELY BRING THE "ON-OFF" SWITCH TO THE "OFF (0)" POSITION (3).**
- **IMMEDIATELY NOTIFY THE "SAFETY MANAGER" (WHERE THE APPLIANCE IS USED IN A BUSINESS CONTEXT) OF THE EMERGENCY.**

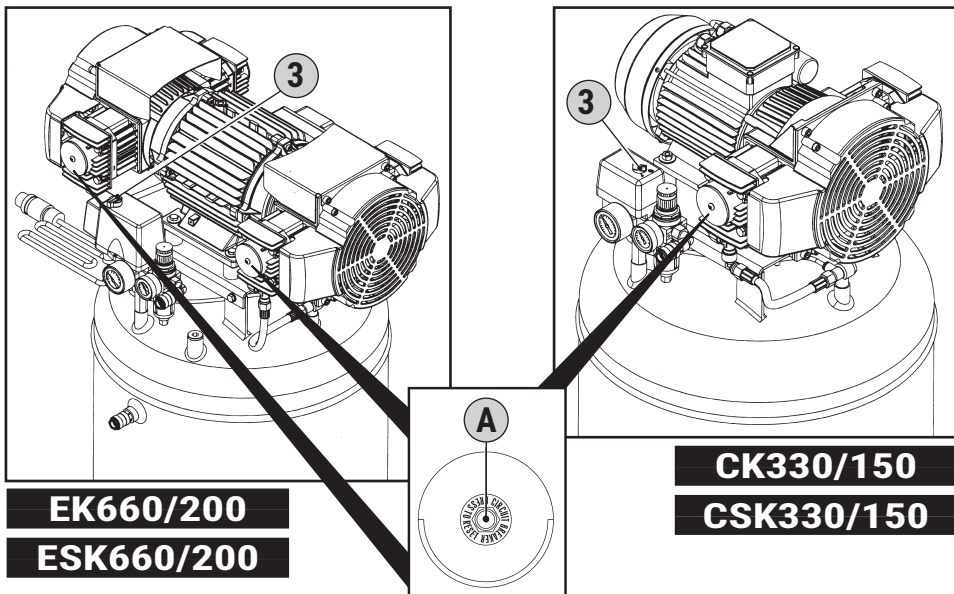



## 30. START-UP SUBSEQUENT TO AN EMERGENCY STOP

After having resolved the issues which offset the emergency, and checked that no damage and/or anomalies have been caused to the appliance, with the consent of the safety manager (where the appliance is used in a business context) start the appliance as described in Paragraph 26.

## 31. STANDARD MAINTENANCE

All activities carried out to ensure use and operation of the appliance, via various intervention types (regulation, valve checks, cleaning of air filters, etc.) executed by the authorised maintenance person according to pre-established time intervals.



**AUTHORISED OPERATORS MUST ONLY CARRY OUT OPERATIONS FOR WHICH THEY ARE QUALIFIED (SEE PARAGRAPH 6) AND WITH THE CONSENT OF THE SAFETY MANAGER (WHERE THE APPLIANCE IS USED IN A BUSINESS CONTEXT).**

**IT IS FORBIDDEN FOR AUTHORISED OPERATORS TO LEAVE THE APPLIANCE UNSUPERVISED DURING OPERATION AND MAINTENANCE INTERVENTIONS.**



STANDARD MAINTENANCE TABLE		
FREQUENCY	INTERVENTION AREA	INTERVENTION TYPE
ONCE A DAY	Safety devices.	Ensure they are intact, correctly installed and functioning.
	Electrical cable and plug.	Visual check of usage status.
	Tank.	Upon termination of each work cycle, rest the appliance on the ground and drain the tank condensate pump opening the condensate pump (A).
EVERY WEEK	Wheels.	Wheel pressure check. Subsequently pump up with compressed air up to a maximum of 2.5 bar.
	N. 4 air filters.	<p>Unscrew the screws (1).</p> <p>Remove the cover (2).</p> <p>Extract the filter (3) and clean it using compressed air.</p> <p>Reassemble the filters and properly reposition the lid.</p> <p><b>NOTE: REPLACE IN THE INSTANCE WHERE IT IS WORN.</b></p>

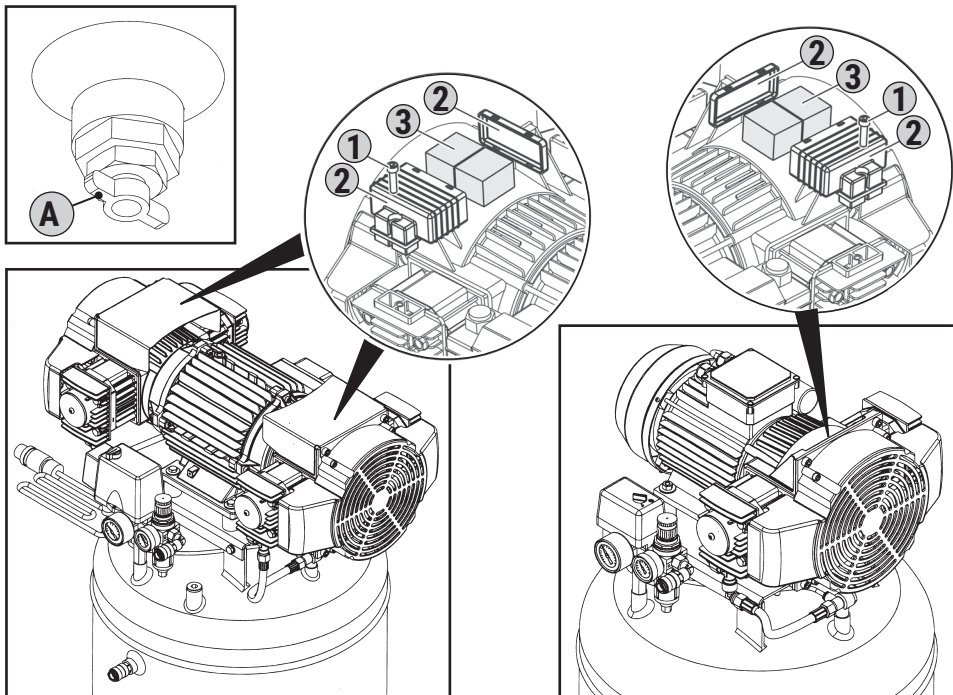



## 32. EXTRAORDINARY MAINTENANCE

All activities carried out to ensure use and operation of the appliance, via various intervention types (regulation, valve checks, cleaning of air filters, etc.) executed by the Manufacturer's technicians according to preestablished time intervals and in the instance of faults or wear and tear.



**IN THE INSTANCE OF EXTRAORDINARY MAINTENANCE, TECHNICAL ASSISTANCE PROVIDED BY THE MANUFACTURER OR THE AUTHORISED SUPPLIER MUST BE REQUESTED.**

## 33. END OF SERVICE LIFE

When disposing of the appliance, current legislation in force must be considered.

Dispose of the various component materials separately (plastic, copper, iron, etc.).

## 34. REPLACEMENT PARTS



**IN THE INSTANCE OF EXTRAORDINARY MAINTENANCE, TECHNICAL ASSISTANCE PROVIDED BY THE MANUFACTURER OR THE AUTHORISED SUPPLIER MUST BE REQUESTED.**

**USING UNORIGINAL REPLACEMENT PARTS IS FORBIDDEN.**

## 35. ANOMALIES - CAUSES - SOLUTIONS

The following table displays various scenarios which may occur when using the appliance.



**AUTHORISED OPERATORS MUST ONLY CARRY OUT OPERATIONS FOR WHICH THEY ARE QUALIFIED (SEE PARAGRAPH 6) AND WITH THE CONSENT OF THE SAFETY MANAGER (WHERE THE APPLIANCE IS USED IN A BUSINESS CONTEXT).**



ABNORMALITIES	CAUSE	SOLUTION
<p><b>The appliance will not start or it stops and will not re-start.</b></p>	<p>No electrical supply.</p>	<ul style="list-style-type: none"> <li>• Check that the switch <b>(3)</b> is in the “ON (I)” position.</li> <li>• Check that the electrical plug is functioning correctly and is correctly plugged in.</li> <li>• Check that any extensions used and the plug are functioning correctly.</li> <li>• Check that the electrical main switch is functioning and in the “ON” position.</li> </ul>
	<p>Intervention of the safety to voltage overload and/or a short-circuit.</p>	<ul style="list-style-type: none"> <li>• Carry out the procedure described in Paragraph 28.</li> </ul>
<p><b>The appliance restarts numerous times even without a utensil.</b></p>	<p>Leakages from the air pipe, utensil or pneumatic system.</p>	<ul style="list-style-type: none"> <li>• Check that the pneumatic system is not damaged.</li> <li>• Check that the air pipe and utensils are intact as well as the connections.</li> </ul>
<p><b>The utensil does not emit air.</b></p>	<p>The tank is not pressurised.</p>	<ul style="list-style-type: none"> <li>• Switch on the appliance and wait until the tank fills checking the pressure of the relevant gauge.</li> </ul>
	<p>Incorrect regulation of the outlet pressure.</p>	<ul style="list-style-type: none"> <li>• Check that the value displayed on the outlet pressure gauge <b>(6)</b> is greater than 0 (zero) bar.</li> </ul>
	<p>The utensil is damaged.</p>	<ul style="list-style-type: none"> <li>• Check that the utensil is intact and effective.</li> </ul>
<p><b>Fall of pressure in the air tank.</b></p>	<p>Leakages in the air pipe, utensil or the pneumatic system.</p>	<ul style="list-style-type: none"> <li>• Check that the pneumatic system is not damaged.</li> <li>• Check that the air pipe and utensil are not damaged.</li> <li>• Check that the appliance-air pipe and air pipe-utensil connections are correct.</li> <li>• Check that the condensate pump is securely closed <b>(A)</b>.</li> </ul>



ABNORMALITIES	CAUSE	SOLUTION
<b>Safety valve intervention.</b>	Pressure switch fault.	• Contact an authorised Supplier.
<b>Air loss from the pressure switch when appliance is off.</b>	Unclean or worn return valve.	• Contact an authorised Supplier.
<b>The appliance vibrates and/or emits lots of noise.</b>	Mechanical fault.	• Contact an authorised Supplier.
<b>Frequent start-ups and low performance.</b>	Unclean air filters.	• Carry out filter cleaning (see Paragraph 31).

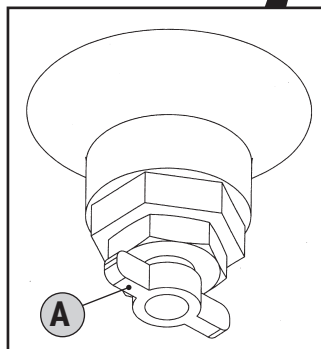
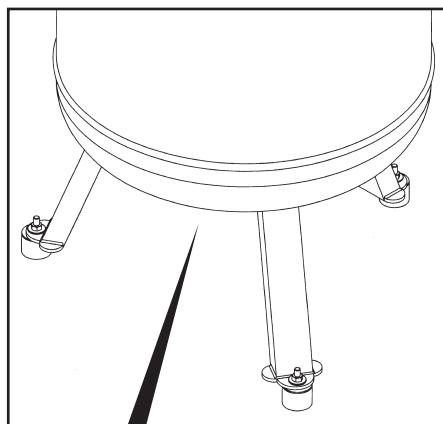
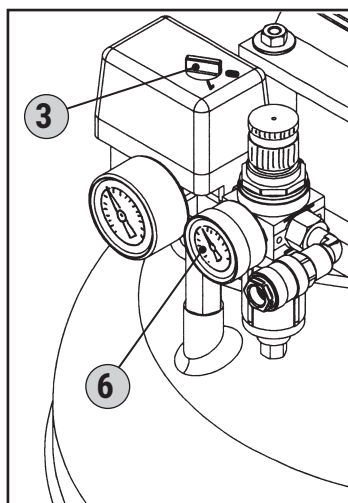



Via delle Tezze, 20/22  
36070 TRISSINO (VI)  
Italy

phone +39 0445 96 20 00  
info@gentilinair.com

[www.gentilinair.com](http://www.gentilinair.com)



41073902

41073902 - 04/2022